



Perfecto



archiproducts[®]
AWARDS
WINNER



INSTRUCTIONS FOR INSTALLATION, USE AND MAINTENANCE



220-240V 50/60Hz

380-415V 50/60Hz

Summary	
I GENERAL	4
II WARNINGS.....	5
III INSTALLATION	8
III.1 AIR TREATMENT	8
III.2 PRELIMINARY INDICATIONS	9
III.3 INSTALLATION	12
III.3.a INSTALLATION OF THE INDUCTION HOB	14
III.3.b CONSTRUCTION INSTRUCTIONS - OUTLET ON PLINTH	18
III.3.c CONSTRUCTION INSTRUCTIONS - REAR DISCHARGE	19
III.3.d ASSEMBLING THE AIR VENTING PIPE	20
III.4 ELECTRICAL CONNECTION	20
IV OPERATION.....	22
IV.1 DESCRIPTION OF THE EXTRACTING INDUCTION HOB	23
IV.1.a TECHNICAL CHARACTERISTICS	23
IV.1.b MAIN CONTROL CHARACTERISTICS OF THE EXTRACTOR HOB	25
IV.2 CONTAINERS FOR COOKING	26
IV.2.a QUALITY OF THE PANS	26
IV.2.b DIMENSIONS OF PANS.....	26
IV.3 INDUCTION HOB.....	27
IV.3.a COOKING ZONE DISPLAY	27
IV.3.b HOB CHARACTERISTICS.....	28
IV.3.c HOB CONFIGURATION	28
IV.3.d HOB OPERATION	32
IV.4 EXTRACTION.....	40
IV.4.a PRELIMINARY INDICATIONS	40
IV.4.b EXTRACTION OPERATION	41
V MAINTENANCE AND CLEANING	44
V.1 CLEANING THE EXTRACTOR INDUCTION HOB	44
VI TROUBLESHOOTING.....	49
VI.1 ERRORS / TROUBLESHOOTING.....	49
VI.2 ASSISTANCE SERVICE	50
VII DECOMMISSIONING	51
VII.1 DECOMMISSIONING	51
VII.2 DISASSEMBLY.....	51
VII.3 PROTECTING THE ENVIRONMENT	51
VII.4 DISPOSAL	51

GENERAL

These user instructions describe the appliance and its use. This instruction manual is an integral part of the appliance itself, therefore it must be carefully stored and ALWAYS kept with the appliance, even in the event of its assignment to another owner or user, or transfer to another installation site.

The appliance may have different aesthetics compared to what is illustrated in the drawings in this manual, however the instructions for installation, use and maintenance remain the same.

The manufacturer strives for continuous improvements.

For this reason, the text and illustrations in this manual may be changed without notice.

II WARNINGS

- The appliance is manufactured according to the safety standards in force.
- Use of the appliance cannot be different from that for which it was built, i.e. as an extractor induction hob, for the cooking of food and the extraction of cooking fumes, installed in domestic kitchens.
- The manufacturer disclaims all liability for any damage caused to persons, animals or property, installation and maintenance errors, or misuse.
- Before connecting the appliance to the mains, check the serial number plate (located on the lower part of the appliance) to make sure that the voltage and power correspond to those of the mains and that the connection socket is suitable. If in doubt, contact a qualified electrician.



Attention! Before any cleaning or maintenance operation or in the event of thunderstorms, disconnect the appliance by setting the main system switch to "off" (Fig.2.1) or by unplugging it (Fig.2.2).

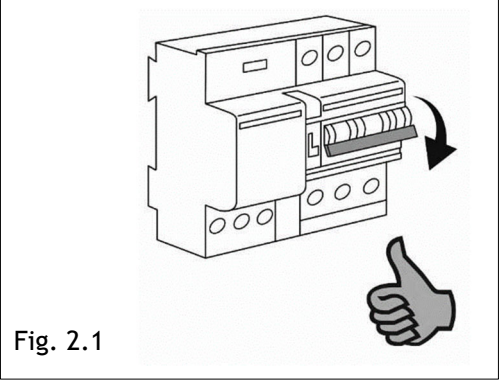

Fig. 2.1

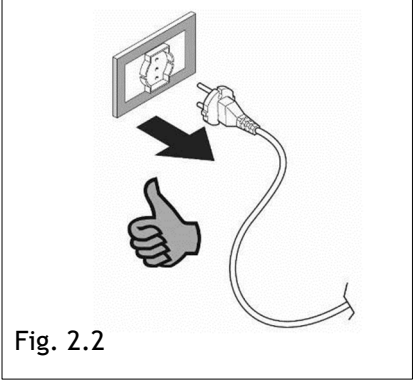
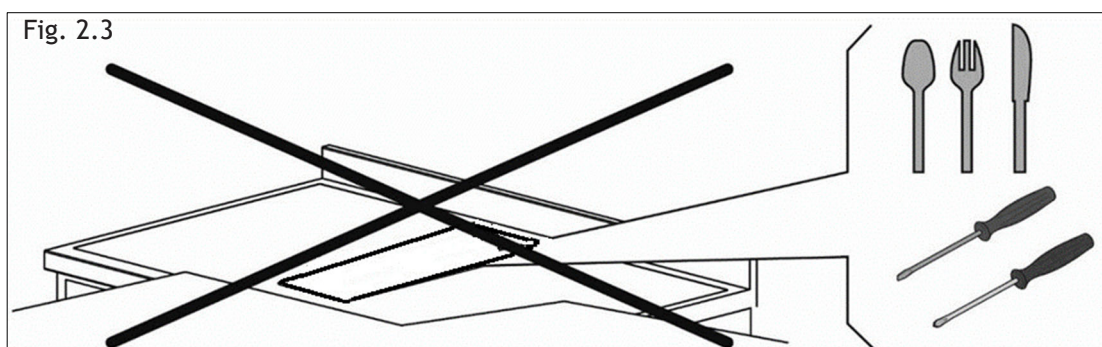
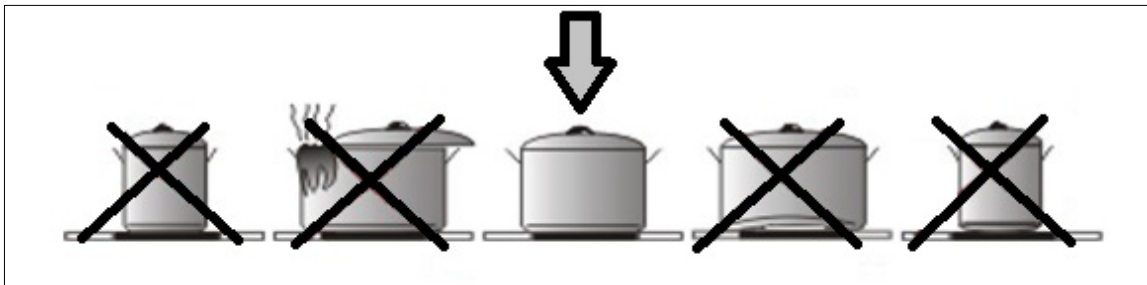

Fig. 2.2

- When the extractor hob is in operation, the parts of the extractor hob adjacent to the induction hobs can also become hot.
- There is a possibility of fire if cleaning operations are not carried out according to the instructions.
- The appliance must not be cleaned with steam or high-pressure cleaners.
- It is forbidden to introduce any object through the glass extraction flap (Fig.2.3).



- Do not use the appliance to heat the room.
- Pay attention to the electrical connection of other appliances in the immediate vicinity that must not come into contact with the hot appliance.
- It is forbidden to pull, detach or twist the electrical cables exiting the appliance, even if it is disconnected from the power supply.
- Cooker hoods and other cooking fume extractors can adversely affect the safe operation of appliances that burn gas or other fuels (including those in other rooms) due to the backflow of flue gases. These gases have the potential to cause carbon monoxide poisoning. After installing a cooker hood or other kitchen fume extractor, flow gas appliances should be tested for function by a competent person to ensure that no backflow of flue gases occurs.
- It is forbidden to cook on the flame.
- To avoid any unwanted interference on the control panel (Touch Control “TC”), position suitable pans centred on the points marked on the glass ceramic surface.



Precautions before use

- Unpack all the materials.
- The installation and connection of the appliance must be performed by authorised specialists. The manufacturer cannot be held responsible for damage caused by installation or connection errors.
- To be used, the appliance must be well equipped and installed in a kitchen unit and on an adapted and approved work surface.
- This appliance is intended solely for the cooking of food and excludes any other domestic, commercial or industrial use.
- Remove all labels and stickers from the ceramic glass.
- Do not change or alter the appliance.
- The hob cannot be used as a free-standing or work surface.
- The appliance must be earthed and wired in accordance with the local standards.
- Do not use any extension cord to connect it or multiple sockets.
- The appliance must not be used on top of a dishwasher or tumble dryer: steam can damage electronic appliances.
- The appliance is not designed to be operated using an external timer or separate remote control system.

Use of the appliance

- After use, switch off the hob using its control device and do not rely on the pot detector.
- Turn off the heating zones after use.
- Be vigilant when cooking with fat or oils that could catch fire quickly.
- Be careful not to burn yourself during or after using the appliance.
- Make sure that there are no cables from any appliance, fixed or mobile, in contact with the glass or hot pot.
- Magnetic objects (credit cards, mobile phones, calculators) must not be placed near the plugged-in device.
- Metallic objects such as knives, forks, spoons and lids must not be placed on the hob surface as they can heat up.
- In general, do not place metal objects except for heating containers on the glass surface. In the event of unexpected or residual overheating, these can heat up, melt or even burn.
- Never cover the appliance with a cloth or protective sheet. This could become very hot and catch fire.
- This appliance may be used by children aged 10 years or over and by persons with reduced physical, sensory or mental capabilities or who lack experience and knowledge only if they have been supervised or instructed in safe use of the appliance and understand the dangers.
- Children must not play with the appliance.
- Cleaning and maintenance by the user must not be performed by children without supervision.

Precautions to avoid damaging the appliance

- Rough pot bases or damaged pans (not enamelled cast iron pans) can damage the ceramic glass.
- Sand or other abrasive materials can damage the ceramic glass.
- Avoid dropping objects, even small ones, on the ceramic glass.
- Do not strike the edges of the glass with pans.
- Make sure that the ventilation of the appliance works according to the manufacturer's instructions.
- Do not place or leave empty pans on glass ceramic hobs.
- Sugar, synthetic materials or aluminium foil must not come into contact with the heating zones. These can cause breakage or other alterations of the glass ceramic glass when cooling: switch on the appliance and remove them immediately from the hot heating zone (be careful: do not burn yourself).
- **WARNING:** unattended cooking on a hob with fat or oil can be dangerous and can cause fires.
- **ATTENTION:** the cooking process must be monitored. A short-term cooking process must be monitored constantly.
- **ATTENTION:** fire hazard: do not place objects on the cooking surface.
- Never place hot containers on the control panel.
- Adequate ventilation must be ensured on the front and back of the unit so that the air can circulate.
- If a drawer is located under the built-in appliance, make sure that the space between the contents of the drawer and the underside of the induction hob is large enough (30 mm). This is essential to ensure correct ventilation.
- Never place flammable objects (e.g. sprays) in the drawer located under the glass ceramic hob. Any cutlery drawers must be heat-resistant.

Precautions in case of equipment fault

- If a defect is found, switch off the appliance and interrupt the power supply.
- If the ceramic glass is broken or cracked, it is necessary to disconnect the appliance and contact the after-sales assistance.
- Repairs must be performed by specialists. Do not open the appliance yourself.
- **WARNING:** If the surface is cracked or fractured, switch off the appliance to avoid the possibility of electric shock.

Other protections

- Make sure that the pot/container is always centred on the cooking zone marked on the hob.
- Wearers of pacemakers must be aware that the magnetic field could affect its operation. It is advisable to ask the retailer or doctor for information.
- Do not use containers made of aluminium or synthetic material: they could melt in the cooking zones that are still hot.
- **NEVER** attempt to extinguish a fire with water, but switch off the appliance and cover the flame, e.g. with a lid or fire blanket.



THE USE OF POOR QUALITY COOKWARE OR ANY INDUCTION ADAPTER PLATE FOR NON-MAGNETIC COOKWARE WILL VOID THE WARRANTY. IN THIS CASE, THE MANUFACTURER CANNOT BE HELD RESPONSIBLE FOR ANY DAMAGE CAUSED TO THE HOB AND/OR TO THE SURROUNDING ENVIRONMENT.



III INSTALLATION

III.1 AIR TREATMENT

This extraction system allows the treatment of cooking fumes. The system can be used in extraction or filtering mode (long life ceramic odour filter kit or kit with plasma filter available separately).



Extracting (external evacuation). Fumes from the kitchen are expelled outside through the pipe (not supplied with the appliance) connected to the motor exhaust fitting.



Attention! In no case must the pipe be connected to combustion exhaust ducts (stoves, boilers, burners, etc.).

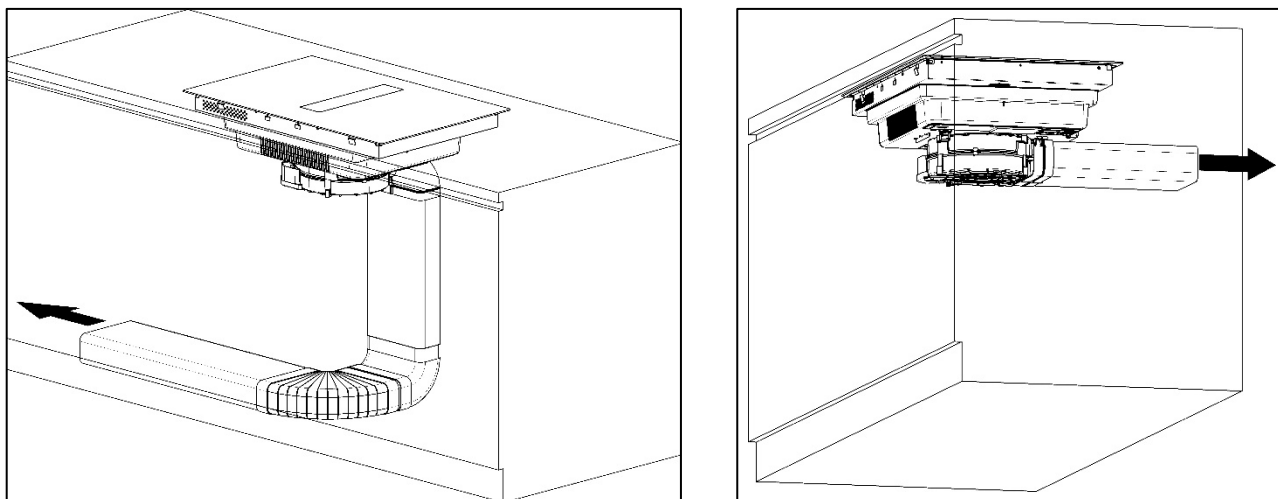

The use of long pipes, with many bends, corrugated and with a smaller section than that of the motor outlet will cause a decrease in extraction performance and a possible increase in noise.



Filtering (internal recycling). The fumes pass through the long life ceramic odour filters (which can be ordered separately as an accessory) to be purified and recycled in the kitchen environment.

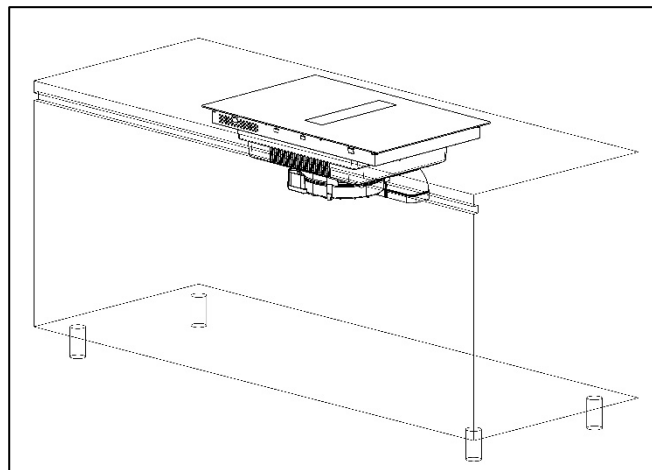
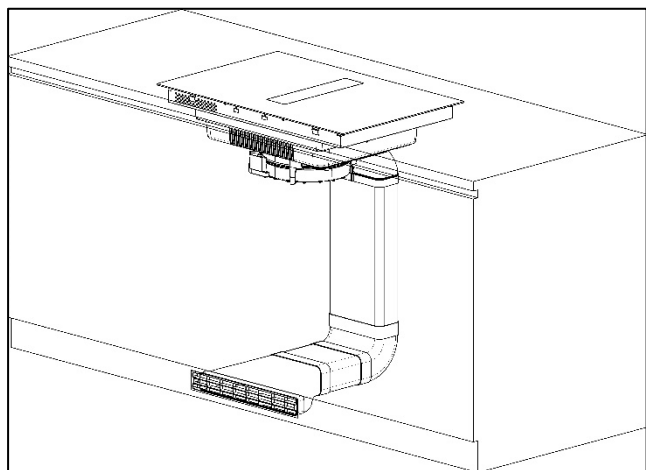

III.2 PRELIMINARY INDICATIONS

Read the entire instruction booklet before installing and using the equipment.

For the installation of the appliance, safety equipment and a series of devices are required as shown in Fig.3.2.1.

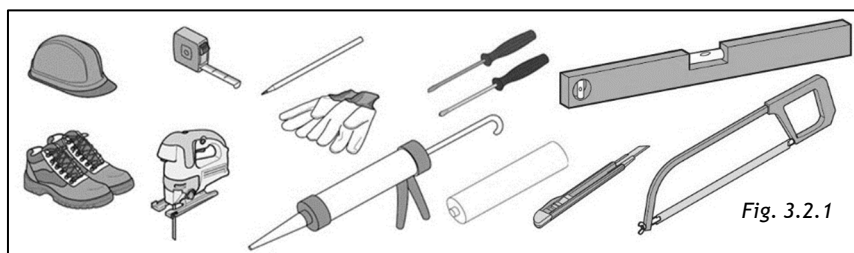
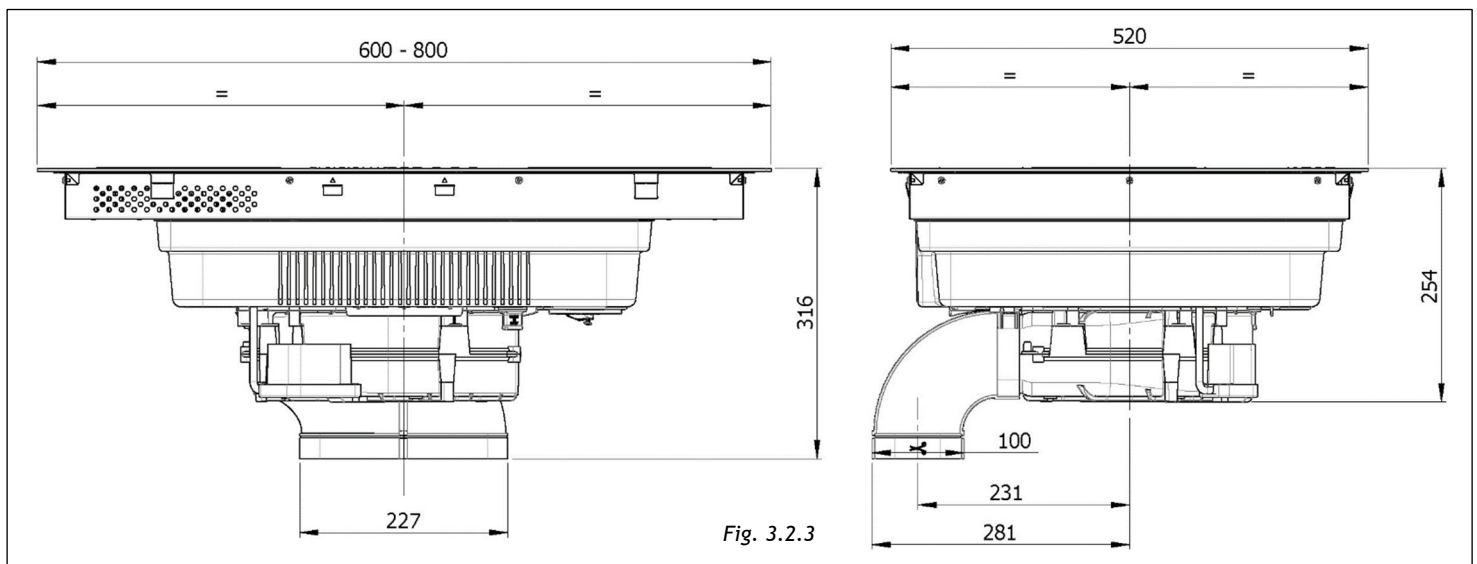
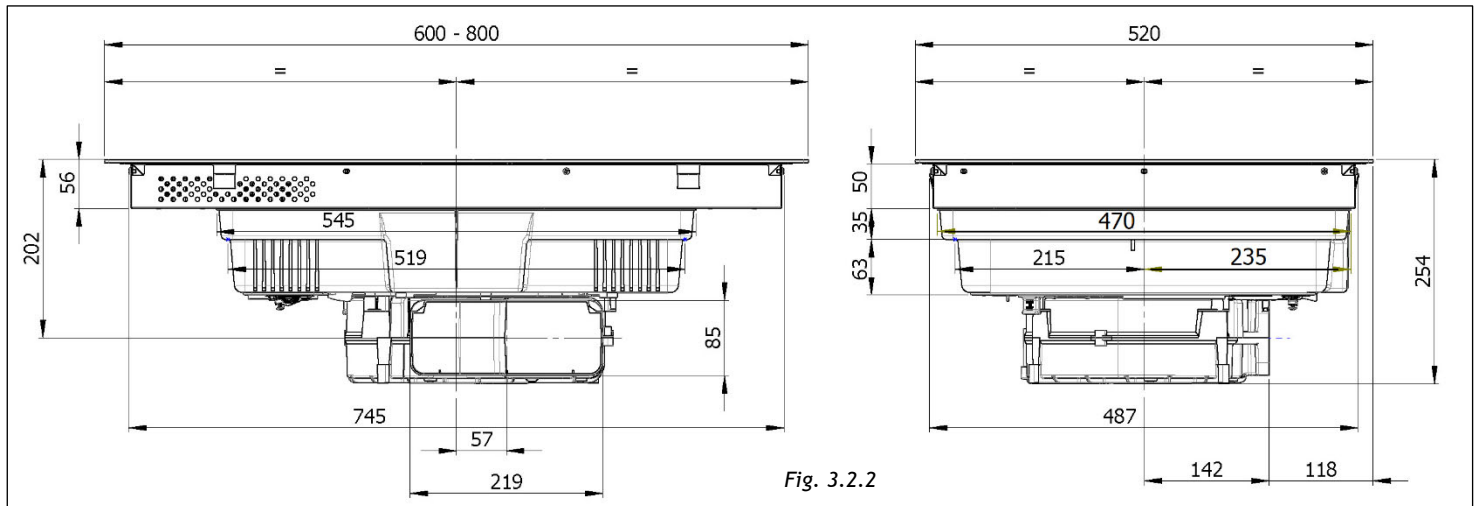

Fig. 3.2.1

The extraction hob is equipped with all the fixings necessary for its installation and suitable for most units.

Attention: check the minimum dimensions of the unit for installation considering the overall dimensions of the appliance indicated in Fig. 3.2.2 and Fig. 3.2.3.



The unit cladding must be treated with heat-resistant glues (100°C) otherwise, due to lower thermal resistance, its shape and colour could change.

Ideally the appliance must be installed without tall units or walls on both sides (Fig.3.2.4-A). The presence of tall units or walls is only permitted on one side of the appliance (Fig.3.2.4-B and Fig.3.2.4-C). It is absolutely forbidden to place units or walls higher than the appliance on both sides (Fig.3.2.4-D), for protection against the danger of fire. The use of wooden decorative slats is not permitted.

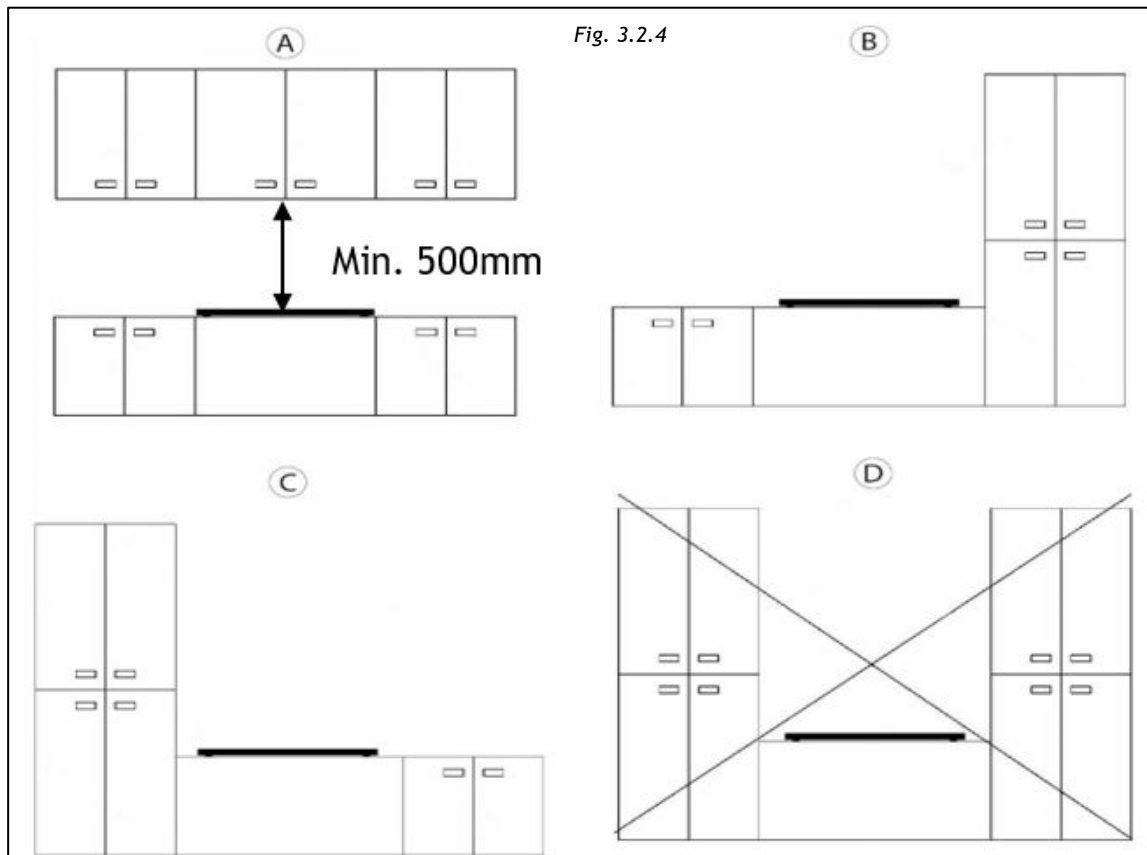

We recommend installing the appliance only after having assembled the wall unit to avoid any damage to the glass top.

The safety space between the hob and any unit positioned above it must respect a minimum distance of 500 mm. (Fig. 3.2.4-A).

III.3 INSTALLATION

Upon opening the box, the installer will be presented with the elements shown below, to be installed according to the method described in these pages.

Front view (Fig. 3.3.1):

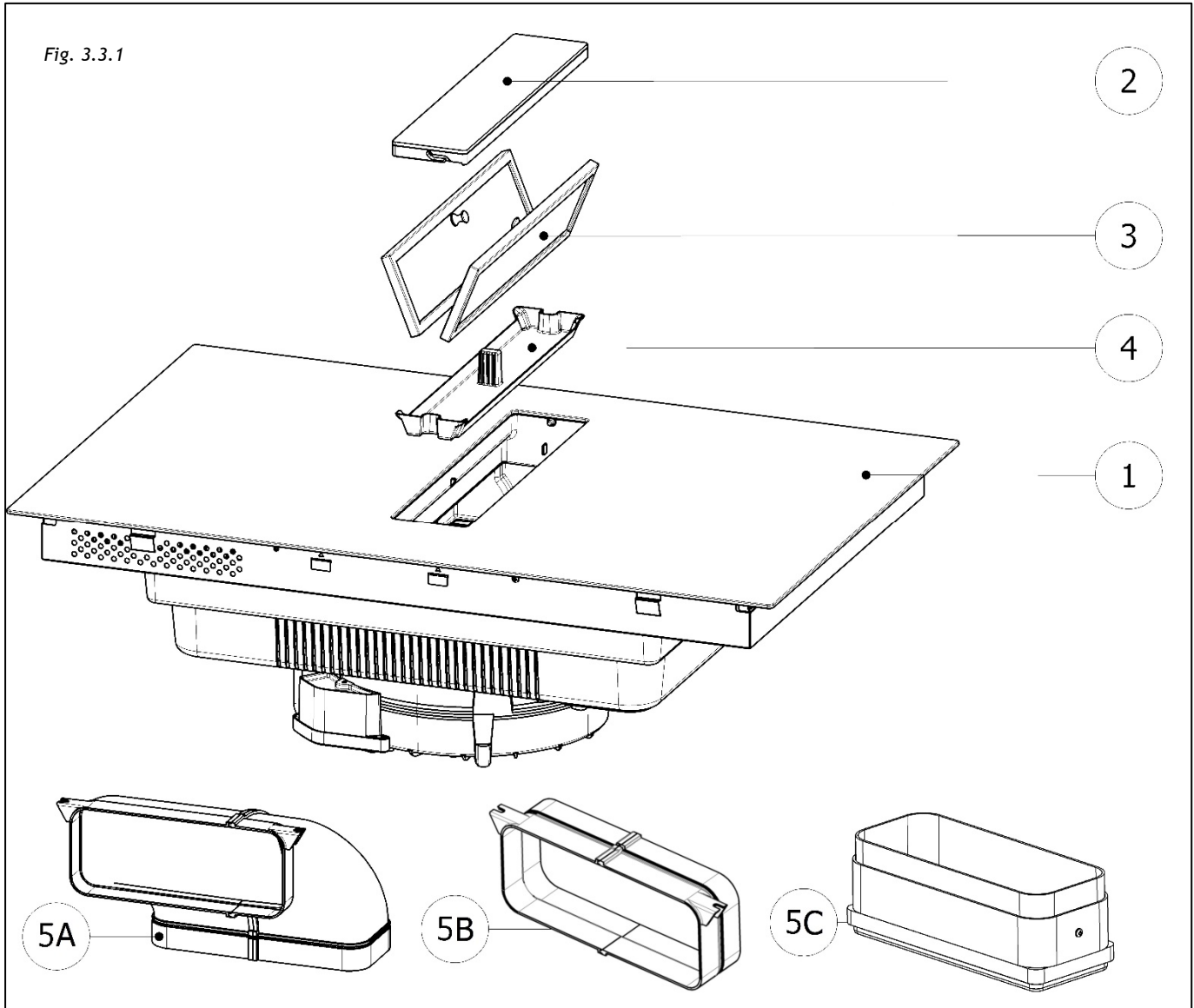

1. Hob
2. Glass flap
3. Grease filters
4. Condensate collection tray
5. Air outlet fitting:
 - A. Outlet on Plinth
 - B. Rear Discharge
 - C. Adapter

Rear view (Fig. 3.3.2):

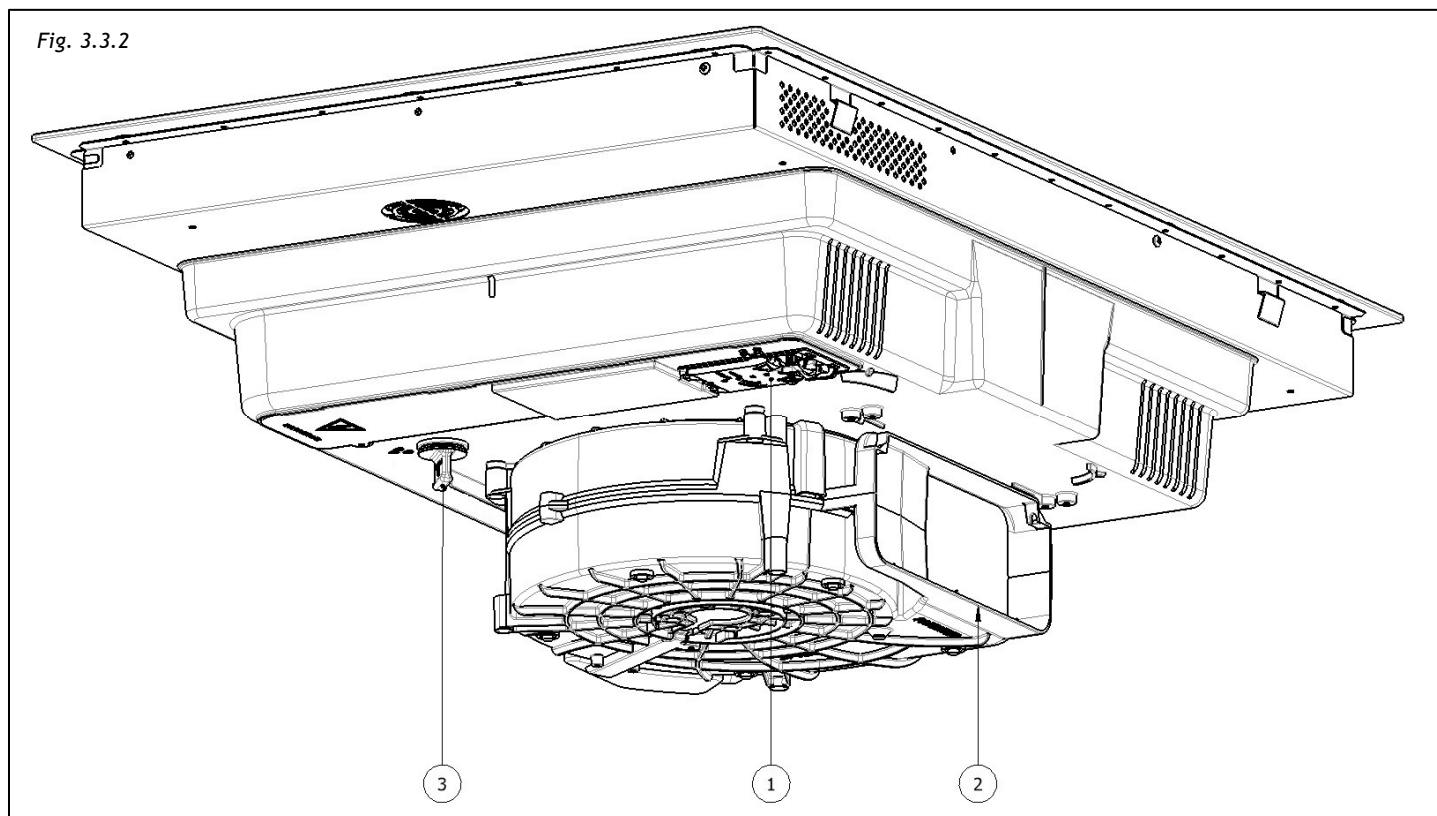

1. Power box
2. Extractor outlet
3. Liquid drain plug

III.3.a INSTALLATION OF THE INDUCTION HOB

To leave the necessary space for the air pipe, it is important to install the induction hob with the centre line more than 300mm away from any wall on the rear.

The induction hob can be installed in two ways either resting on the work surface or flush with the work surface.

To perform LAY-ON INSTALLATION, drill the top as shown:

Fig. 3.3.a.1-A -> 60cm hob.

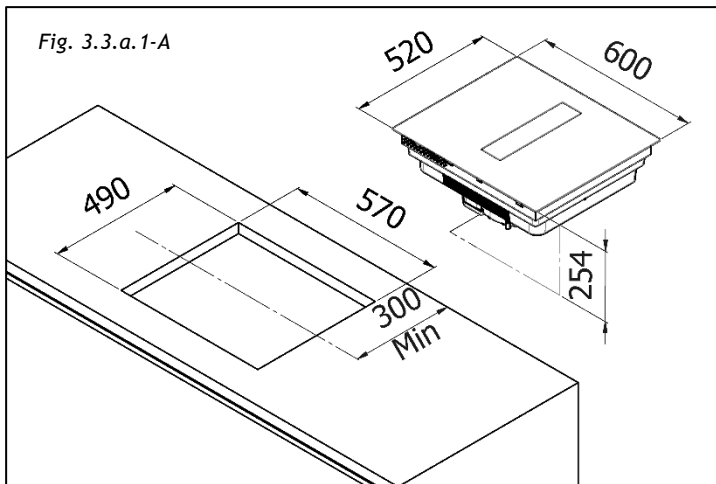
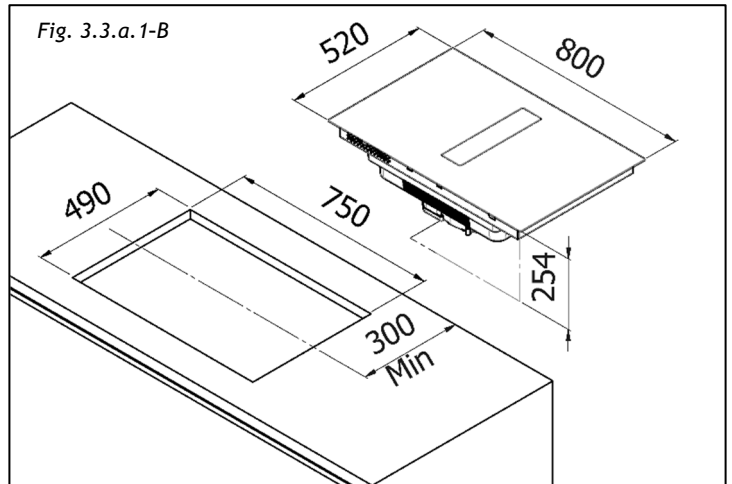

Fig. 3.3.a.1-B -> 80cm hob.



To perform FLUSH INSTALLATION, drill and mill the work surface along the edge of the installation hole, respecting the measurements indicated:

Fig. 3.3.a.2-A -> 60cm hob.

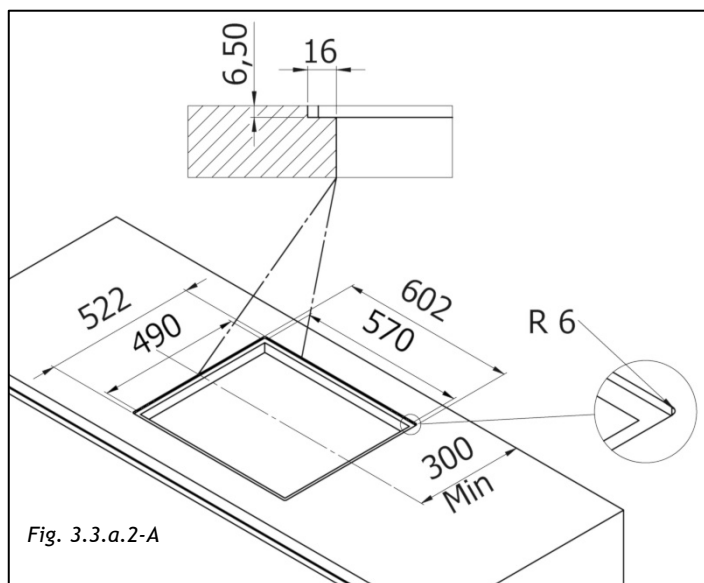
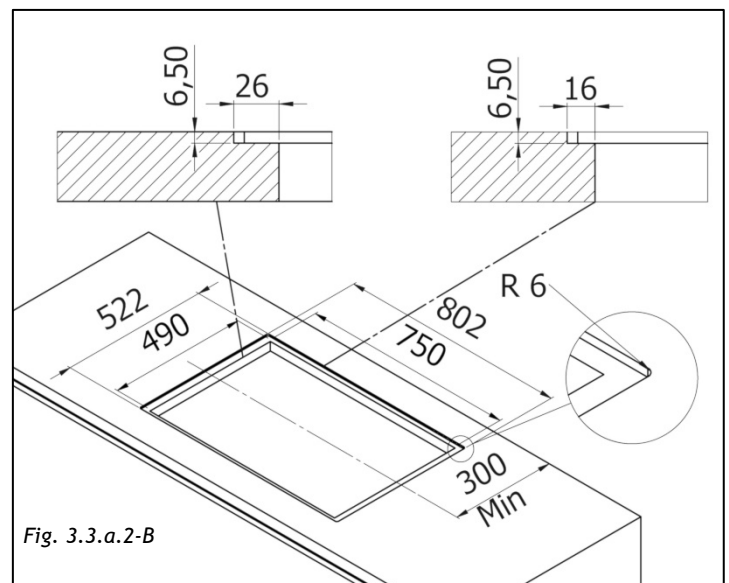

Fig. 3.3.a.2-B -> 80cm hob.



The installation is under the sole responsibility of the specialists.

The installer is required to comply with the legislation and standards in force in their country of origin.

Materials are often used to expand work surfaces in contact with water. To protect the cut edge of the unit, apply a coat of varnish or special sealant. Particular care must be taken when applying the adhesive seal supplied with the hob to prevent leaks in the support unit. This seal ensures a proper seal when used in conjunction with smooth work surfaces.

How to attach the seal:

The seal supplied with the hob prevents all liquid infiltration into the unit. Its installation must be performed carefully, respecting the following drawing.

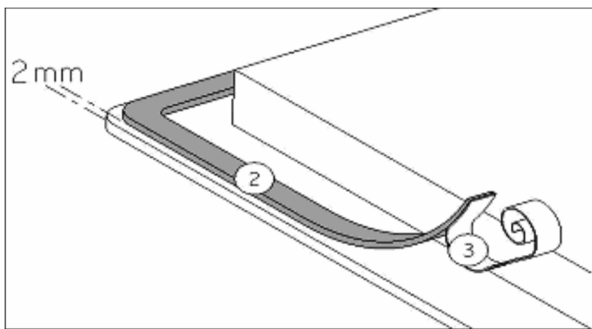

Attach the seal (2) two millimetres from the outer edge of the glass, after removing the protective sheet (3).

Assembly - installation:

- **Make sure there is a distance of 50mm between the hob and the wall or sides.**
- Ideally the hob should be installed with plenty of space on both sides. There may be a wall to the rear and tall units or a wall to one side. **On the other side, however, no unit or divider should be higher than the hob.**
- The unit or support into which the hob is to be installed, as well as the edges of the unit, the laminate coverings and the glue used to fix them, must be able to withstand temperatures of up to 100°C.
- The edge wall rods must be heat-resistant.
- The product must not be installed above cooling devices, dishwashers, stoves, ovens, washing machines, or dryers.

Attach the air fitting (Fig. 3.3.a.3-1) on the extractor outlet with the two screws supplied.

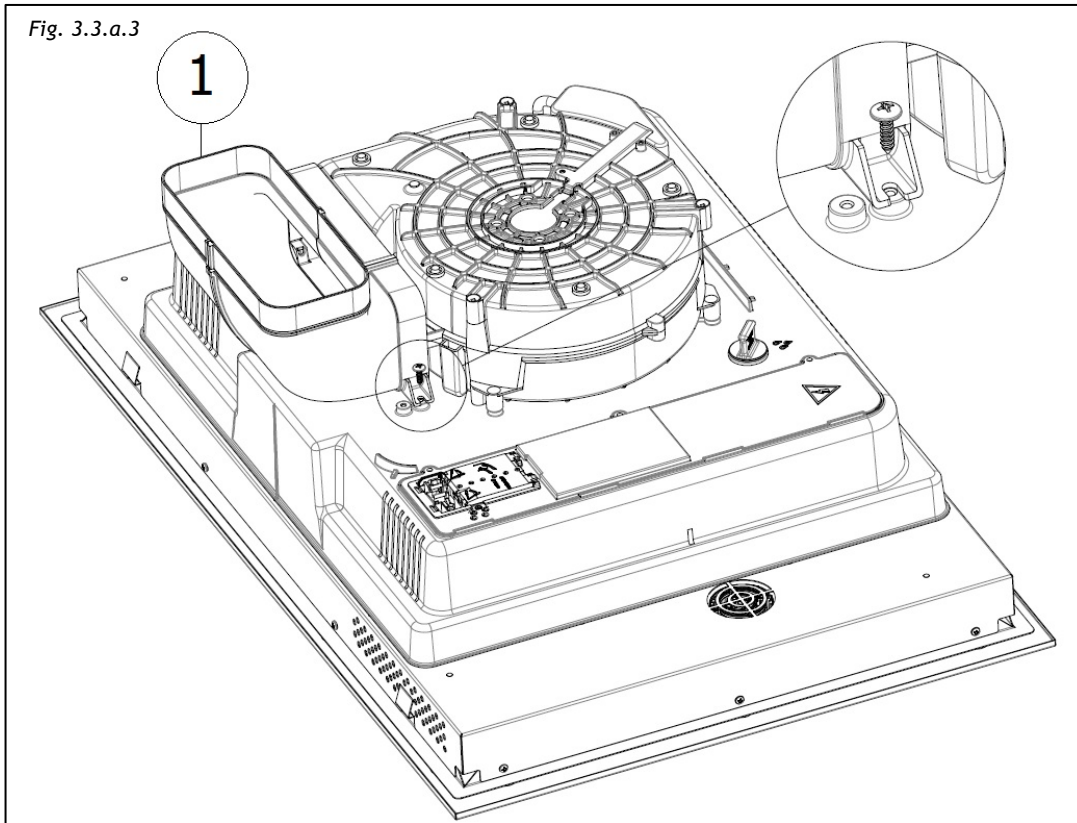

Support the hob (Fig.3.3.a.4)

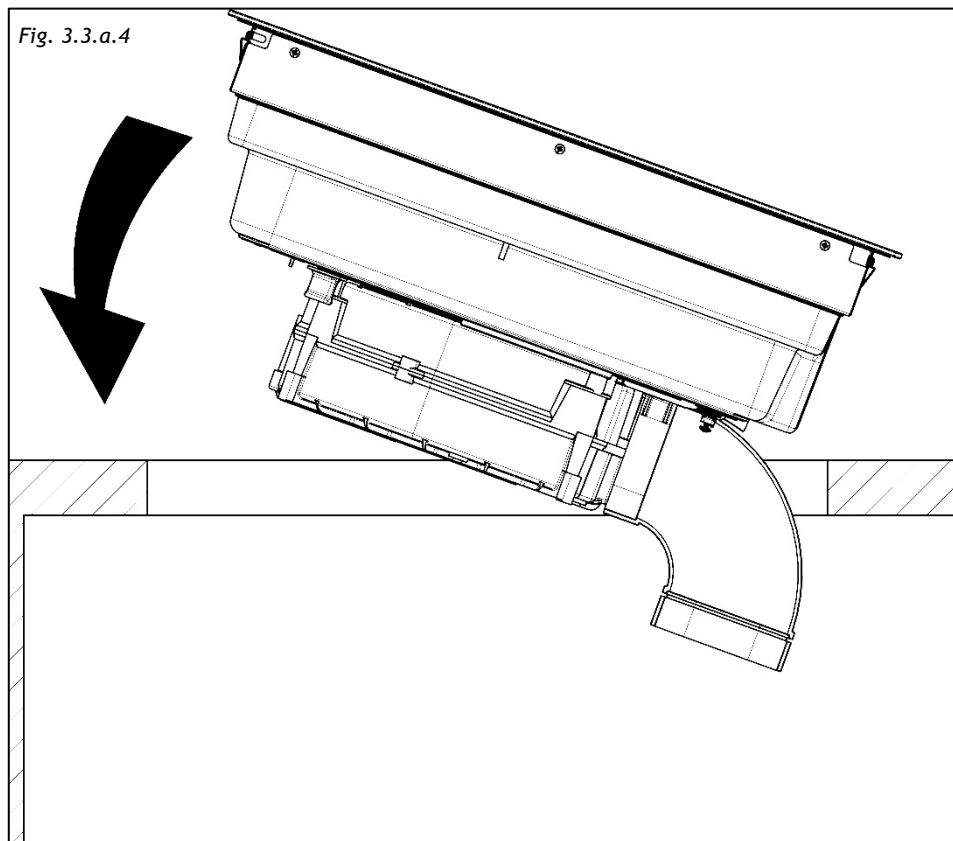

It is necessary to ensure adequate ventilation on the front and rear of the unit, making sure that the air is able to circulate through the various air intakes as indicated below in the figures:

Fig. 3.3.a.5-A -> 60cm hob. (5 air intakes)

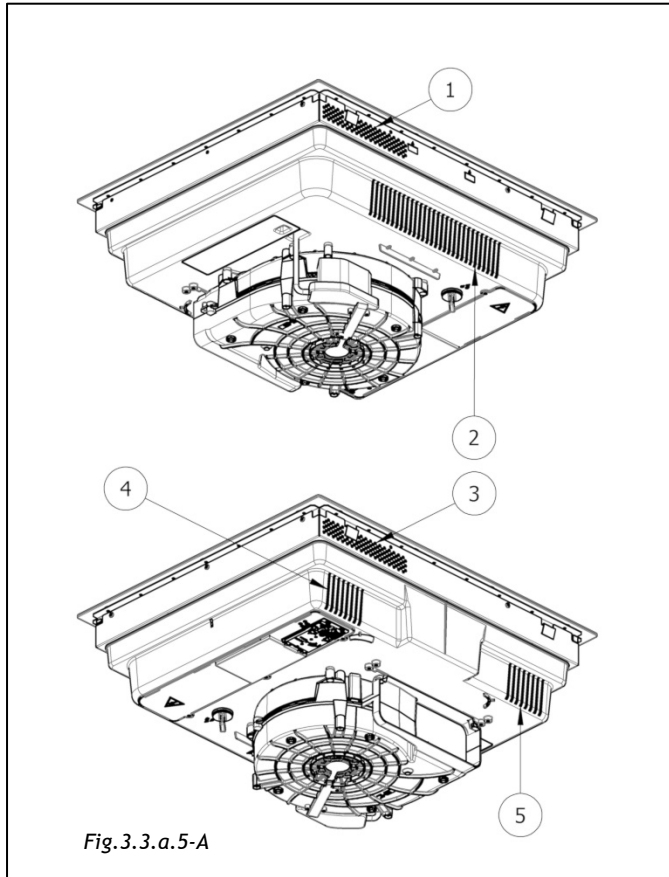
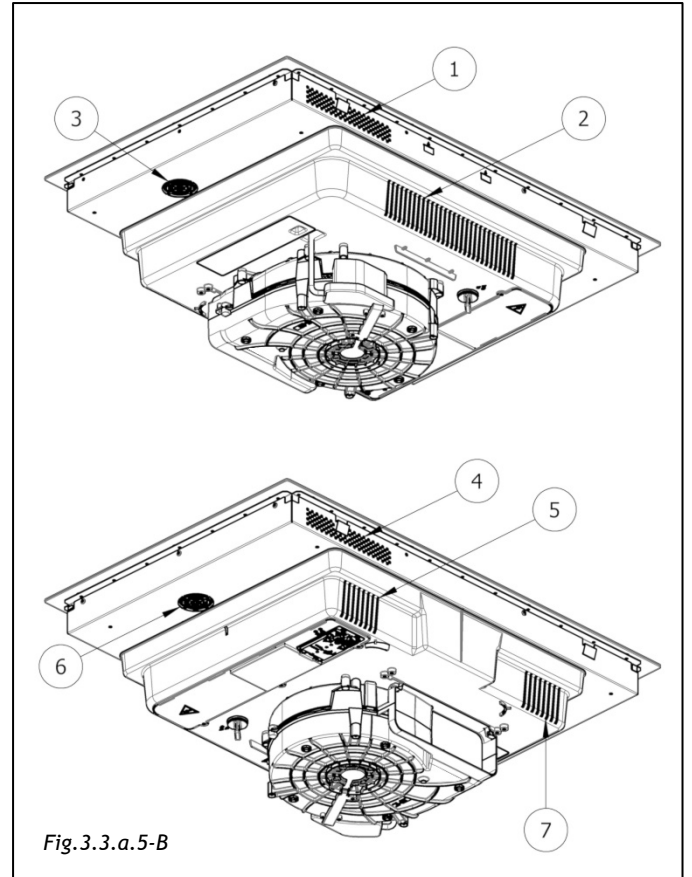

Fig. 3.3.a.5-B -> 80cm hob. (7 air intakes)



- If a drawer is under the hob, to ensure good air circulation and a good cooling system of the appliance, maintain a space of at least 30 mm between the ventilation of the lower part of the hob and what is placed inside of the drawer.
- If a drawer is positioned under the hob, avoid placing flammable items (for example: sprays) or non-heat resistant items in this drawer.
- After installation, the connection cable must not be subjected to any mechanical stress, such as due to a drawer.

III.3.b CONSTRUCTION INSTRUCTIONS - OUTLET ON PLINTH

To convey the air into the plinth it is necessary to create a vertical pipe parallel to the back of the unit. Appropriately sized accessories, pipes and fittings are available, please contact the manufacturer.

To ensure a correct connection between the extractor outlet (Fig. 3.3.2-2) and the duct, use the supplied connector and, if necessary, the included adapter, as shown in Fig. 3.3.b.1.

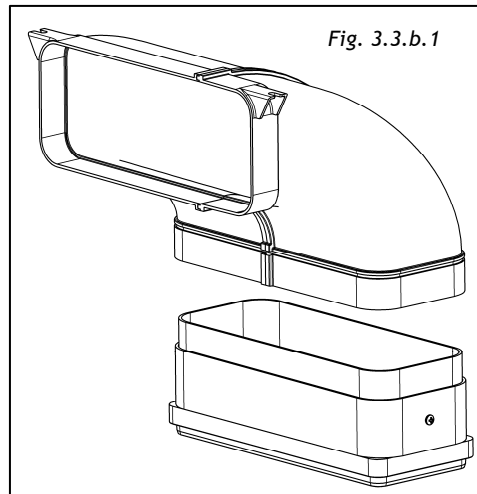

To allow the vent pipe to be seated correctly, if it is provided under the plinth of the unit, the outlet should be created in the base as shown in Fig. 3.3.b.2 and the rear panel possibly removed.

The introduction of this extraction system on a unit with a depth of 600mm implies a maximum possible length for any drawers provided under the hob of approximately 450mm. If the depth of the unit is greater, the underlying drawers will also have a wider length.

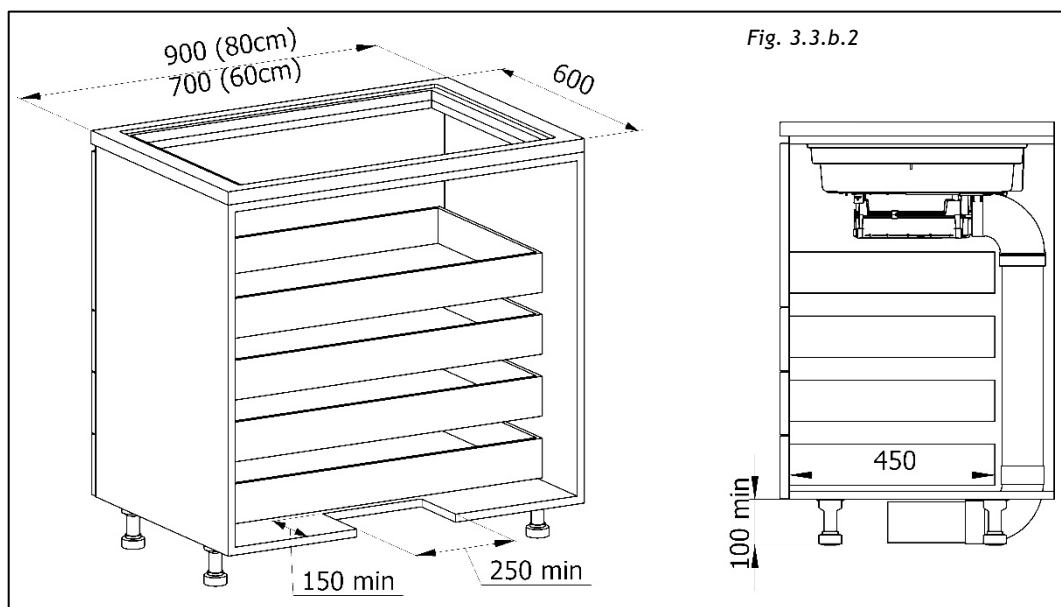

III.3.c CONSTRUCTION INSTRUCTIONS - REAR DISCHARGE

To convey the air to the rear, it is necessary to create a horizontal pipe perpendicular to the back of the unit. Appropriately sized accessories, pipes and fittings are available, please contact the manufacturer.

To ensure a correct connection between the extractor outlet (Fig. 3.3.2-2) and the duct, use the supplied connector and, if necessary, the included adapter, as shown in Fig. 3.3.c.1.

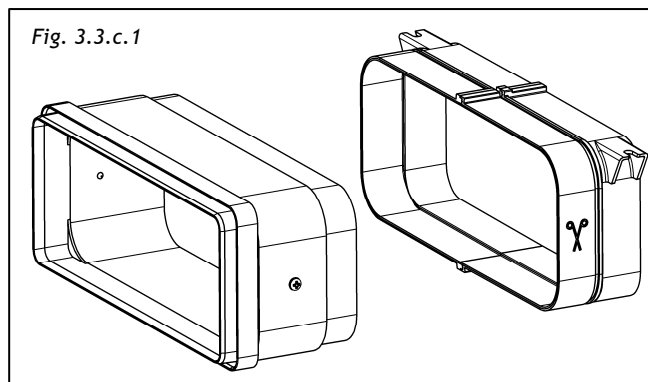

To allow air to be vented to the rear, the outlet should not be created on the base of the unit. The outlet should be created through the rear panel as indicated in Fig. 3.3.c.2 or the latter possibly removed.

On a unit with a depth of 600 mm, the maximum possible length for any drawers provided under the hob is approximately 550 mm. If the depth of the unit is greater the underlying drawers will also have a wider length.

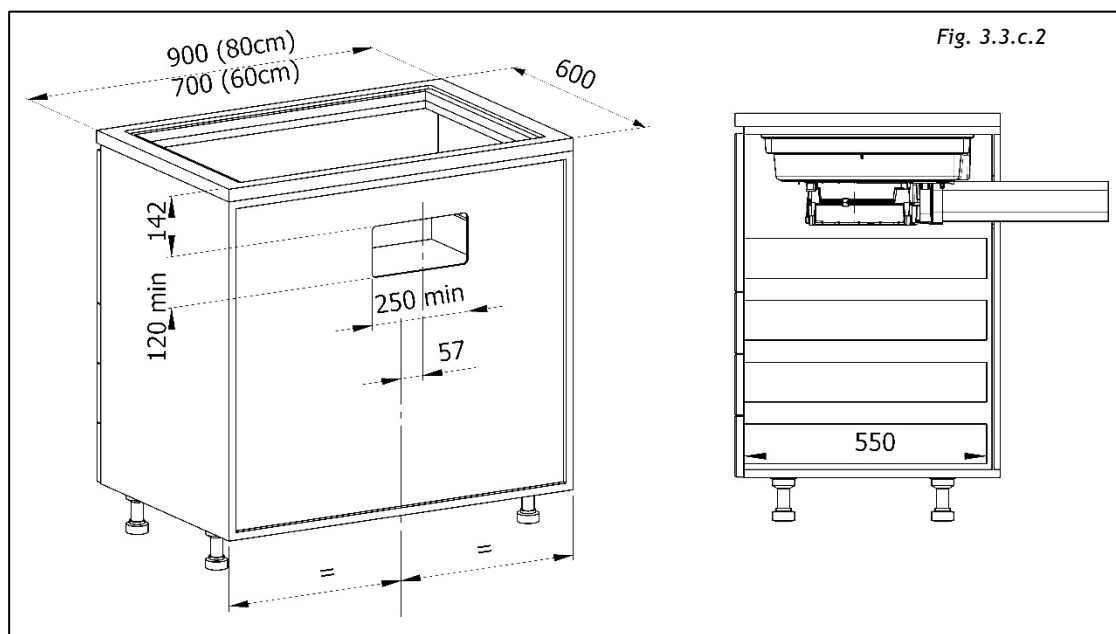

III.3.d ASSEMBLING THE AIR VENTING PIPE

To bring the air outlet to the desired position, it will be necessary to install the pipe using fittings that can be purchased separately (Fig. 3.3.d.1).

To purchase these accessories, ask the manufacturer for them.

The entire pipe must necessarily pass under the base of the unit, in the space of the plinth riser.

Our accessories also allow the installation of filtering kits.

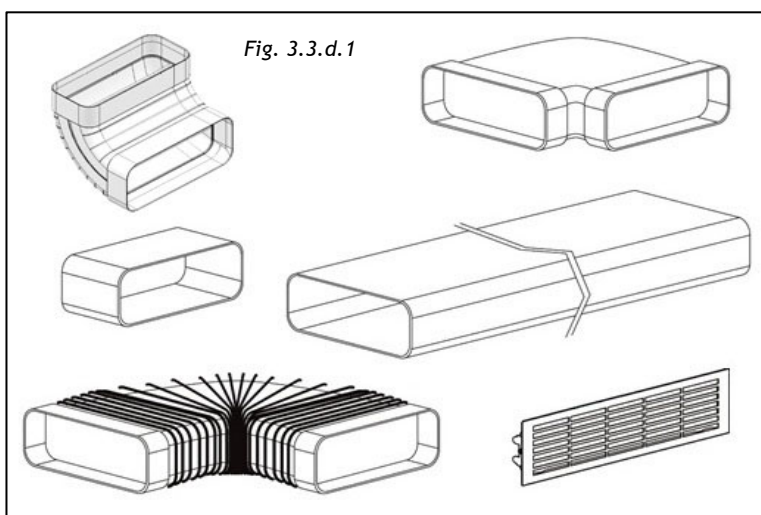

III.4 ELECTRICAL CONNECTION

The electrical connection must **ONLY** be performed by specialist technicians.

The electrical protection of the electrical connection upstream of the appliance must comply with the standards in force.



Attention! Make sure that the voltage (V) and frequency (Hz) indicated on the serial number plate inside the appliances correspond to those available in the place of installation.

Any modifications that may be necessary to the electrical system to install the appliance must only be performed by competent persons.

After installation, the insulated parts and those carrying electric current must be protected from possible contact.



Attention! If the electrical connection is performed incorrectly or not according to the standards, parts of the appliance can be damaged and the warranty will be invalidated.



Attention! Before any intervention, disconnect the appliance from the mains (Fig. 2.1- Fig. 2.2 WARNINGS chapter).

These appliances must be connected to an earthed system.

The appliance must be connected to the electrical mains system, interposing an omnipolar switch which ensures disconnection from the network, with an opening distance of the contacts which allows complete disconnection under the conditions of overvoltage category III, in compliance with the installation rules (Fig.3.4.1).

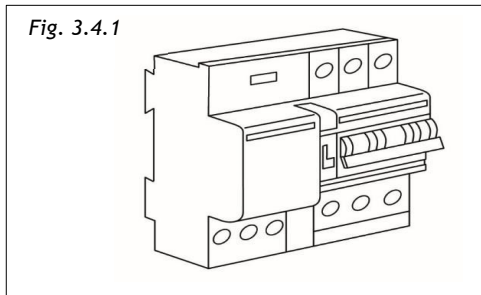

The earth connection (yellow-green cable) must never be interrupted.

The power cable must be long enough to allow connection of the appliance, built into the appliance, to the mains. If the power cable is damaged, it must be replaced in order to prevent any risk.

We cannot be held responsible for any accidents resulting from incorrect connection or which may arise from using an appliance which has not been earthed or which has been fitted with a faulty earth connection.

Protection against live parts must be ensured after installation.

Connection to the mains must be made using an earthed plug or an omnipolar circuit breaker device with a contact opening of at least 3 mm.

The power cable must be positioned in such a way as not to touch the hot parts of the hob or anything else.

Type of connection	Included cable	Cross-section of the included cable	Alternative cable	Cross-section of the alternative cable
SINGLE-PHASE	H05V2V2-F	5x1,5	H05V2V2-F H07RN-F	3x2,5
TWO-PHASE/THREE-PHASE			H07RN-F	5x1,5

At no point should the cable reach a temperature 50°C higher than ambient temperature.

The appliance is intended to be permanently connected to the electricity mains.

Attention! Comply with the following connection diagram (Fig. 3.4.2):

Fig. 3.4.2

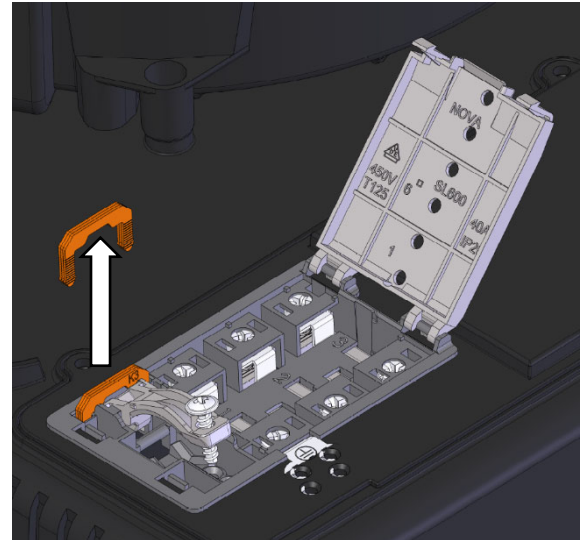
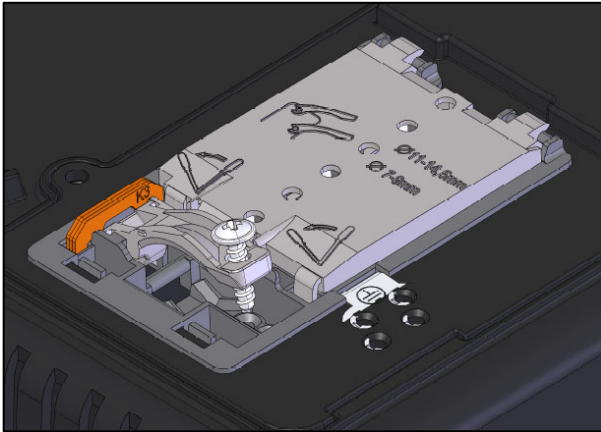

SINGLE-PHASE
1x32 circuit breaker
220-240V
1+N+GND

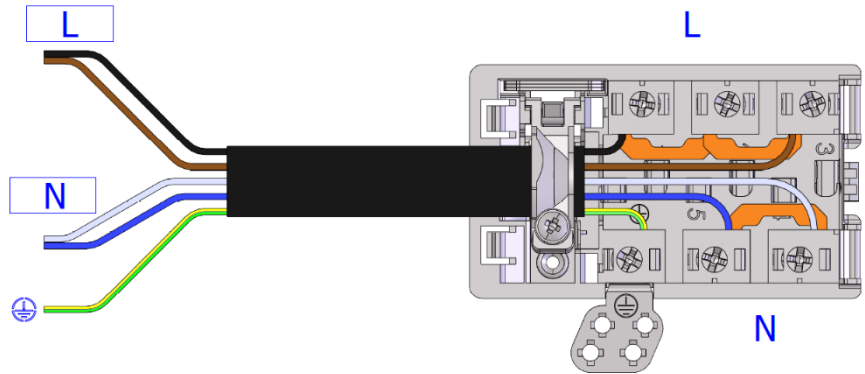

TWO-PHASE
2x16 circuit breaker
230-415V
2+N+GND

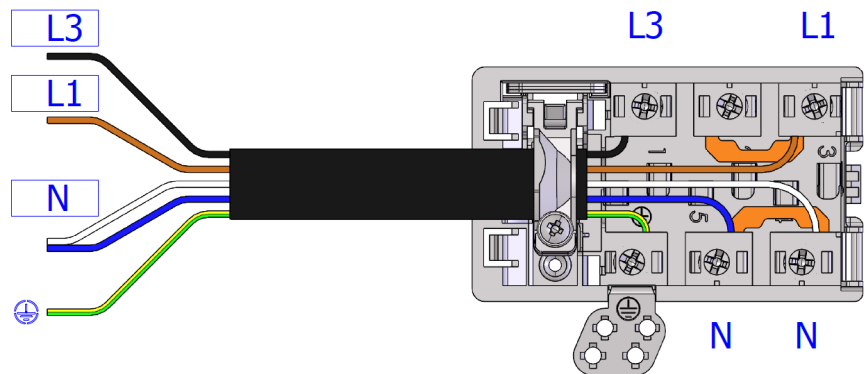

THREE-PHASE
3x16 circuit breaker
380-415V
3+N+GND

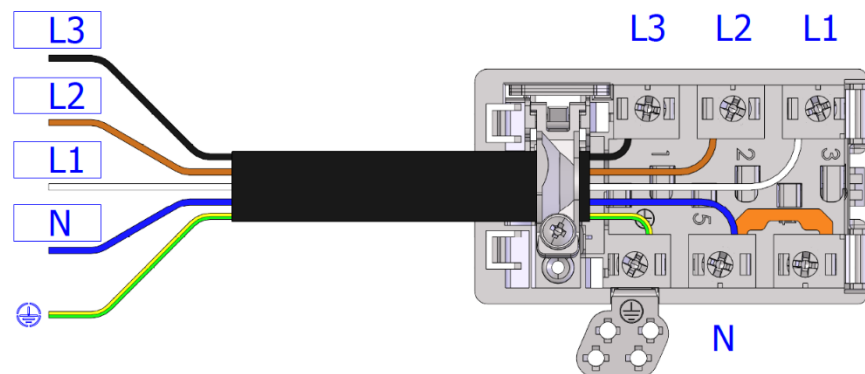

IV OPERATION

IV.1 DESCRIPTION OF THE EXTRACTING INDUCTION HOB

IV.1.a TECHNICAL CHARACTERISTICS

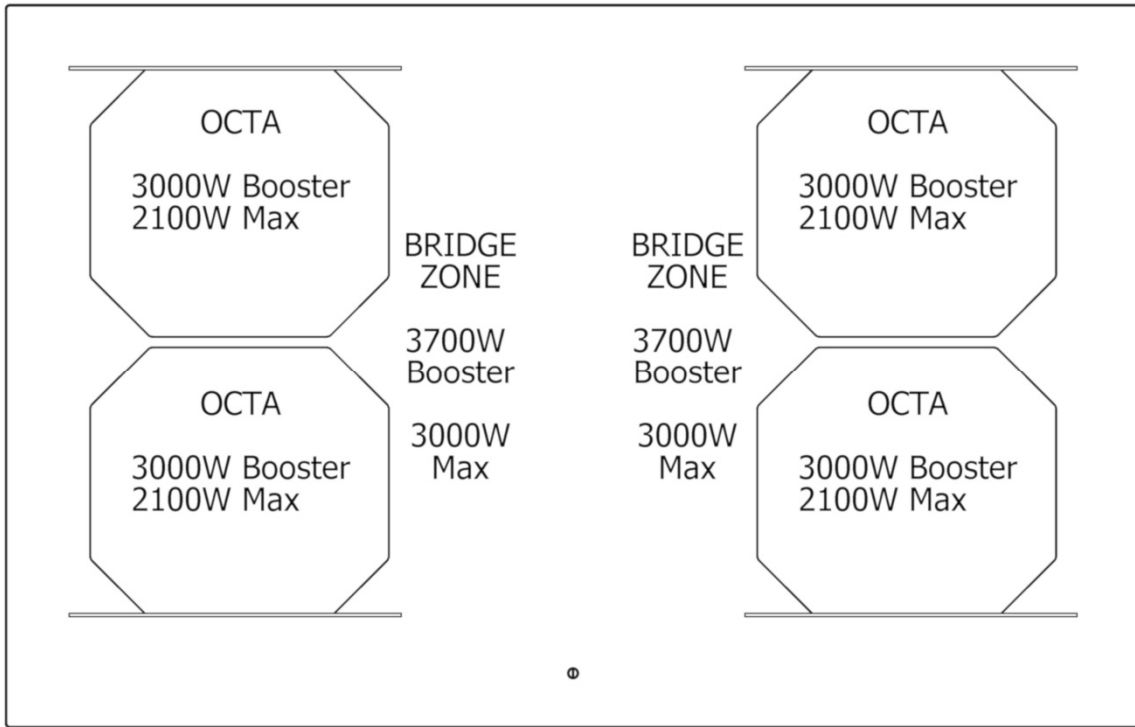

Parameters	Value
Single-phase connection voltage	220 - 240V 1N
Two-phase connection voltage	230 - 415V 2N
Three-phase connection voltage	380 - 415V 3N
Frequency	50Hz / 60Hz
Max power consumed	7.4 kW Adjustable power, see on HOB CONFIGURATION, User menu
Fuse / single-phase mains connection	1 x 32A
Fuse / connection to the two-phase network	2 x 16A
Fuse / connection to the three-phase network	3 x 16A
Dimensions (width x depth x height)	60cm. -> 600 x 520 x 254mm 80cm. -> 800 x 520 x 254mm
Net weight (hob only)	60cm. -> 19.0 kg. / 80cm. -> 20.0 kg.
Gross weight (including packaging)	60cm. -> 27.5 kg. / 80cm. -> 29.5 kg.
Hob	
Surface material	Glass ceramic
Power level	1 - 9, P
Cooking zone dimensions	OCTA 210 x 190mm
Max-booster cooking zone power level	2100W - 3000W
Hob energy consumption (pot size)	
Front left cooking zone (FL)	187.3 Wh/kg
Front right cooking zone (FR)	187.3 Wh/kg
Rear left cooking zone (RL)	187.3 Wh/kg
Rear right cooking zone (RR)	187.3 Wh/kg
Total (on average)	187.3 Wh/kg
Extraction system	
Power level	1 - 9, P

IV.1.b MAIN CONTROL CHARACTERISTICS OF THE EXTRACTOR HOB

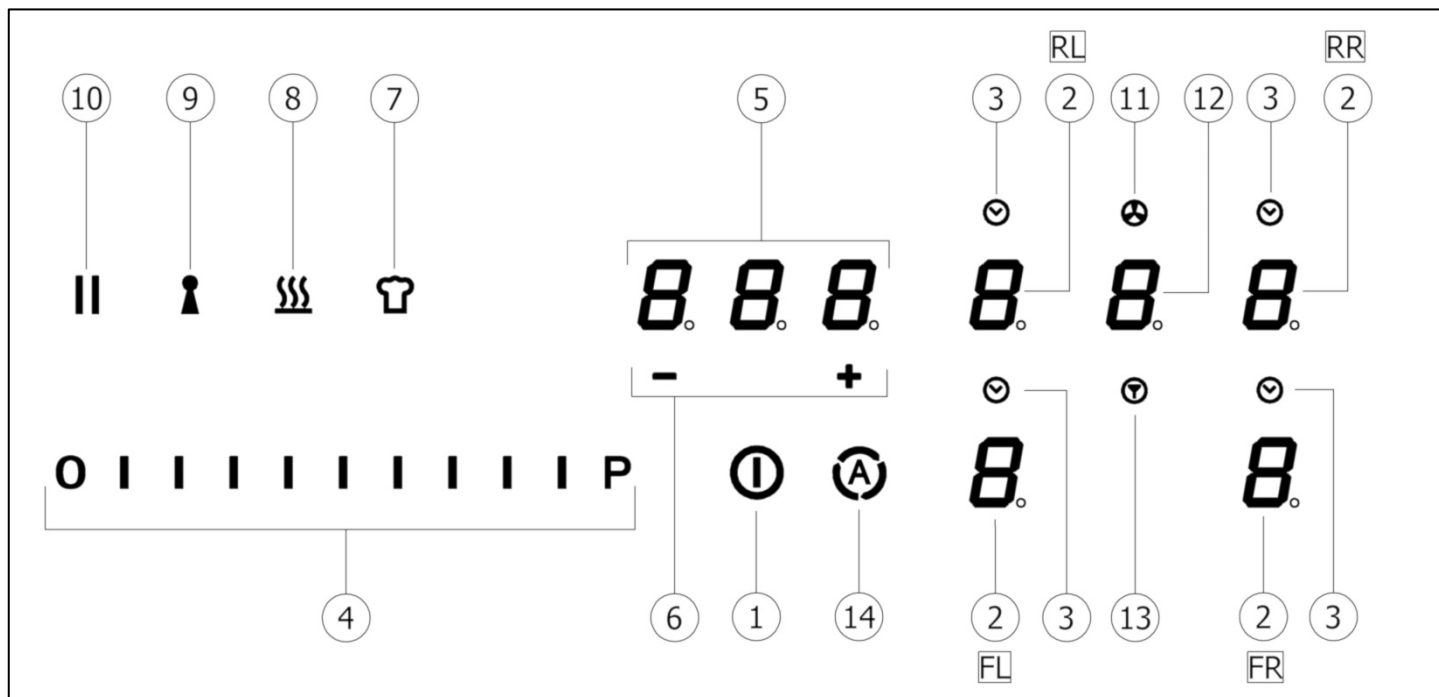

CONTROL PANEL (TOUCH CONTROL "TC")

Touch keys (Touch) / Display

1. ON/OFF of the hob/extractor system
2. Cooking zone selection / Cooking zone display:
 - 2FL → Front Left
 - 2FR → Front Right
 - 2RL → Rear Left
 - 2RR → Rear Right
3. Cooking zone timer activation / Active cooking zone timer indicator
4. Increase/Decrease cooking power level and extraction speed (power) / Display of cooking power level and suction speed (power)
5. Activation of Independent Timer / Independent Timer Display / Cooking zone timer display
6. Independent Timer time increase/decrease / Cooking zone timer display
7. Activation of the "Chef cook" function
8. "Warming" function activation
9. "Keylock" function activation
10. "Pause" function activation
11. Active extractor indicator
12. Selection/activation of extractor / Extractor display
 - Long life ceramic odour filter saturation - grease filter display
13. Filter saturation reset
14. Activation of extractor automatic function

IV.2 CONTAINERS FOR COOKING

IV.2.a QUALITY OF THE PANS

Only use pans bearing the symbol 

Suitable materials: steel, enamelled steel, cast iron, ferromagnetic stainless steel, aluminium with a ferromagnetic base.

Unsuitable materials: aluminium and stainless steel without ferromagnetic base, copper, brass, glass, ceramic, porcelain.

Manufacturers specify whether their products are induction compatible.

To check if the pans are compatible:

- Add some water to a pot positioned on an induction heating zone set to the minimum level. This water must heat up in seconds.
- A magnet sticks to the bottom of the pot.

Some cookware can make noise when placed on an induction cooking zone. This noise does not mean that there is a fault with the appliance and it will not affect the cooking operation.

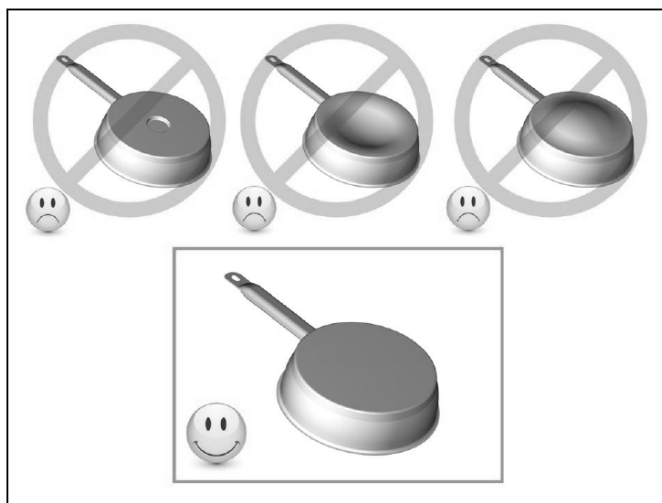

IV.2.b DIMENSIONS OF PANS

The minimum recommended diameter of the pans to be used is:

Function active	Minimum pot diameter
Single cooking area	Ø 110 mm
“Bridge” cooking zone	Ø 230 mm

The bottom of the pot must never touch the central glass flap.

To obtain the best efficiency of the hob, position the suitable pot well centred in relation to the cooking zone marked on the glass ceramic surface.

IV.3 INDUCTION HOB

Important:

All functions of this hob are designed to comply with the most stringent safety regulations.

For this reason:









- Some functions are not activated, or are deactivated automatically, if there are no pans on the burners or when they are incorrectly positioned.
- In other cases the activated functions will be automatically deactivated after a few seconds, if the specific function requires a further setting that has not been selected (e.g.: “Turn the hob on” without “Selecting the cooking zone” and the “Operating temperature”, or the “Lock Function” or the “Timer” function).

Attention! In the case (for example) of prolonged use, the cooking zone may not immediately shut down because it is in the cooling phase; the “H” symbol will appear on the cooking zone display, to indicate the execution of this phase.

Wait for the display to switch off before approaching the cooking zone.

IV.3.a COOKING ZONE DISPLAY

The following is shown on the cooking zone displays:

Cooking zone on	
Power level	 (P=Power Booster)
Residual heat display	
Pot Detection	
Bridge function active	
Warming function active	
Pause function	
Chef Cook Function	

IV.3.b HOB CHARACTERISTICS

➤ **Permanent Pot Detection:**

The hob is only activated in the presence of pots on the cooking zones. Heating does not start, or stops, if pots are absent or removed.

➤ **Pot Detector:**

The hob automatically detects the presence of pots on the cooking zones.

➤ **Safety Shutdown:**

For safety reasons, each cooking zone has a maximum operating time which depends on the power level set.

➤ **Residual Heat Indicator:**

When one or more cooking zones shut down, the presence of residual heat is indicated by a visual signal on the corresponding zone display, by way of the “H” symbol.

➤ **Acoustic feedback (Beep)**

Function activation acoustic signal

IV.3.c HOB CONFIGURATION

Before use, the Touch Control Panel of the hob, it must be set up to suit your personal requirements.

Note: When the hob is powered on, the symbol  will flash for 2 minutes. This does not indicate any malfunction. During this time, the cooktop can be used normally.

➤ **USER MENU**

From the user menu it is possible to modify certain functions of the control panel such as power level adjustment, brightness adjustment, the volume of the key tones, the volume of the notification sounds, the control panel lighting, the timer animation, etc.

To access the User Menu, the control panel (hob control display) must be in standby mode (off).

User Menu Access:

-> Touch ON/OFF to turn on the Control Panel, then touch ON/OFF again within 3 seconds to turn off.

-> The || key (Pause) starts pulsing for a maximum of 60 seconds (if no action is taken, the attempt to enter the menu is automatically exited after these 60 seconds).

-> Press the || key (pause) without releasing it.

-> Press the display of each cooking zone clockwise as shown in Fig. 4.3.c.1, again without releasing the Pause key, starting from the display of the left front cooking zone 2FL (1-2-3-4).

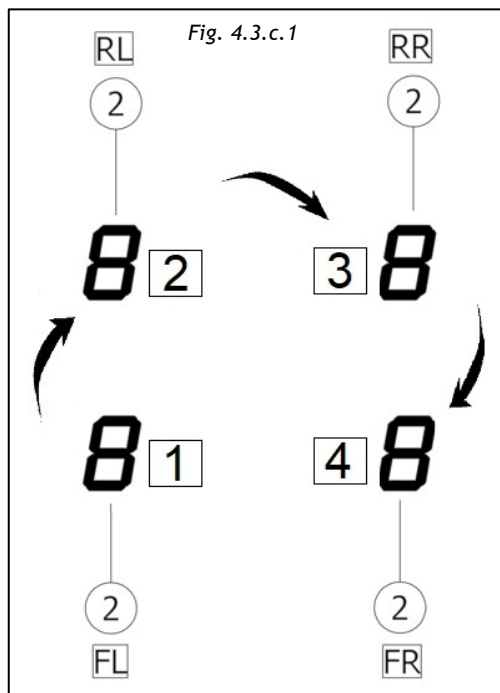

-> Each key press will be confirmed by an acoustic signal (beep).

-> Release the || key (pause) that pulsed.

-> The user menu is active.

-> The rear left cooking zone display (2RL) flashes “U0” (“U” and “0”).

-> Select the menu item to be viewed/modified using the slider (4) as summarised in the table Fig. 4.3.c.2.

For example, to go to U4 (display brightness), press 2RL on the display and select level 4 with the touch slider (the fourth slider bar starting from the left) **0 | | | |**

Now therefore U4 flashes intermittently.

-> At this point the left front display (2FL) is selected where the set value and any variation possibilities are displayed.

In the example of the brightness setting, after having selected the left front display (2FL), all the bars up to 9 will appear on the slider and the number will appear on the display (2FL) with a permitted value, in this case from 0 to 9 (in other cases there may be fewer values, for example in U3 there are only values from 0 to 3) **0 | | | | | | | | |**

Then the selected value of the corresponding selected element is shown on the display of the front left cooking zone (2FL), after which change the value by touching the slider.

Exiting from the User Menu:

-> **Exit without saving:** Touch the || key (Pause).

All changes are discarded and the || key stops flashing.

-> **Exit with Save settings:** Touch the power ON/OFF key for 2 seconds.

The changes are saved and the || key stops flashing.

Note: The user menu exits automatically if no operation is performed for 1 minute.

Overview of the user menu items

The following table (Fig. 4.3.c.2) provides an overview of the user menu items:

Fig. 4.3.c.2			
Display Rear Left (2RL)	Meaning	Display Front Left (2FL)	Note
U0	Power regulation 	Adjustable from >1.4kW upwards with 0.1 kW step	Maximum configured power by default: Value 0 -> 7.4 kW (Value X->X.X kW if otherwise configured during installation via Service Menu) 1st step, select timer central display (5) where the set power value is lit up (for example 7.4); 2nd step, scroll with the slider (4): <u>->To decrease the value:</u> press and hold, or press repeatedly, the first left-lit segment on slider (4) until you reach the desired value. <u>->To increase the value:</u> press and hold, or press repeatedly, the last right-lit segment on slider (4) until you reach the desired value.
U1	Filter Setting: Grease filter or Odour filter with or without 5-minute Adjustable and Delayed self-switching Off (it is an extraction function at level 1 after the hob has been switched off cooking is completed)	0,1,2,3	Default Filter setting -> 0 0: Grease filter with Adjustable and Delayed self-switching Off 5 minutes 1: Grease filter and odour filter with Adjustable and Delayed self-switching Off 5 minutes 2: Grease filter without Adjustable and Delayed self-switching Off 3: Grease filter and odour filter without Adjustable and Delayed self-switching Off

U2	Volume for button tones	0,1,2,3	<p>Volume adjustment for button tones:</p> <p>0: No button tone 1: minimum volume 2: half volume 3: maximum volume (default)</p> <p>Notes:</p> <ul style="list-style-type: none"> • For regulatory reasons, the button tones for power on and off cannot be disabled. They will sound at the last volume level that was set before disabling the button tones. • Error tones are always played at maximum volume (setting 3) and cannot be disabled.
U3	Volume for signal tones	0,1,2,3	<p>Adjusting the volume of the acoustic signals (e.g. when the timer expires):</p> <p>0: No button tone 1: minimum volume 2: half volume 3: maximum volume (default)</p>
U4	Display brightness 	0,1,2,3,4,5,6,7,8,9	<p>Display brightness adjustment:</p> <p>0: maximum brightness (default) 9: minimum brightness</p>
U5	Timer animation	0,1	<p>0: No timer animation 1: The timer is animated 10 minutes before it expires (default)</p>
U6	Permanent pot detection		Cannot be deactivated
U7	Behaviour when the Timer expires	0,1,2	<p>0: Acoustic signal for 120 sec. (default) 1: Acoustic signal for 10 sec. 2: No tone</p>

IV.3.d HOB OPERATION

Before selecting any function, it is necessary to activate the desired zone.

➤ Switch-on/off

The extractor hob is turned on by touching the ON/OFF key (1) for a few seconds.

The symbol will light up 

By keeping this key pressed, all the available functions will become visible for a few moments, then only the main functions will remain active.

While using the hob, the other functions will also be activated and can be used.

All the available functions will be illuminated with low intensity, which will only increase when they are activated.

To switch off, touch the ON/OFF key (1) for a few seconds.

Important: This function has priority over all the others, therefore it is possible to switch off the hob at any time.

The hob switches off automatically after 20 seconds if all the cooking levels are set to 0 and no operation is in progress.

➤ Selection of cooking zones

Touch the Selection/Display area (2) corresponding to the desired cooking zone.

➤ Power level: increase/decrease

The hob is equipped with 9 power levels.

Touch and slide your fingers along the Selection Bar (4) to increase or decrease:

→ to the right to increase the power level;

← to the left to decrease the power level.

The power level set will be displayed in the Selection/Display area (2)

➤ "P" Booster Function (Enhanced Level)

The hob is equipped with an additional power level (Booster, in addition to level 9) which remains active for 5 minutes and then the power returns to the lower level (9).

This function is useful for heating or boiling a large quantity of water.

To activate the Booster function, slide with your fingers along the selection bar (4), beyond level 9 and activate the Booster function. The "P" symbol will appear on the Display (2).

By activating the Booster (P) on two cooking zones on the same side (2FL+2RL or 2FR+2RR) the first zone of the two activated will automatically switch to lower power to balance the maximum power permitted for each side. To change the cooking zone on which to leave the Booster active, simply select it and take it to level P; the other will automatically be brought to lower power.

Attention: since the Booster function can reach high temperatures, it must only be used for cooking with the use of water. Oil or fat may start burning if the booster function is used.

➤ Key Lock function

The Key Lock function blocks the hob settings, to prevent accidental tampering, leaving the functions already set active.

To activate it, touch the key  (9); to deactivate it, press the same key again.

If any other function is selected while Key Lock is active, the symbol  will remain on a steady light to indicate that the function is active. Then deactivate the function to be able to act on the hob.

➤ Child Lock function

The Childproof lock is a feature to protect the hob from undesirable operations, for example by children. If it is locked, the hob can be switched on, but it is not possible to select the cooking zone, neither the heating level nor the timer. The cooking zone displays will show the symbol .

The childproof lock can only be activated once after switching on. Once activated and deactivated, the child lock cannot be activated a second time. Only after switching ON/OFF can the childproof lock be activated again.

The childproof lock remains active even if the supply voltage is interrupted and recovered. It must be deactivated manually.

Activation:

- > Switch on the hob (Key 1).
- > Press and hold the display of any cooking zone (2) for 3 seconds. Then release the Display.
- > The scroll bar (4) lights up sequentially.
- > Slide the slider cursor from 0 to 9 within 10 seconds.
- > The childproof lock is activated. All the cooking zone displays show .

Deactivation:

- > Switch on the hob (Key 1).
- > Press and hold the display of any cooking zone (2) for 3 seconds. Then release the display.
- > The scroll bar (4) lights up sequentially.

Slide the slider cursor from 9 to 0 within 10 seconds.

The childproof lock is deactivated. The hob switches to operating mode and can be operated normally.

➤ Chef Cook Function

The Chef Cook function is used to set different cooking levels in the cooking zones.

The following power levels are set and dissipated as soon as a suitable pot is placed on the cooking zones:

Rear left cooking zone ->(2RL): Level **5** - Rear right cooking zone ->(2RR): Level **6**

Front left cooking zone ->(2FL): Level **2** - Front right cooking zone ->(2FR): Level **8**

To start the Chef Cook function, as soon as the hob is switched on, it is first necessary to activate at least one cooking zone at any power. Subsequently, the function can be activated and deactivated at any time, until the hob is switched off.

Notes:

The power levels cannot be set by the user.

The operating time limit for the Chef Cook function is 2 hours.

While the Chef Cook function is active, the "pot detection" symbol is removed.

While the Chef Cook function is active, the Bridge function cannot be activated.

Activation:

- > The hob is switched on.
- > Touch the Chef Cook function key (7).
- > The Chef Cook mode is activated.
- > The cooking zone displays (2) show the set power levels:
 - 2RL -> 5 - 2RR -> 6
 - 2FL -> 2 - 2FR -> 8

Deactivation:

- > Touch the Chef Cook function key (7).
- > The Chef Cook mode is deactivated.
- > The power levels for all the cooking zones are set to 0.

➤ Automatic Heat-Up function (Rapid heating)

This function is used to reheat a cold pot with full heating power and to automatically return to the desired cooking level. It will therefore be possible to cook faster without the risk of burning the food. The function can be activated for power levels from 1 to 8.

The time to reach full power in the cooking zone depends on the cooking level selected and mentioned in the table below. The heating times are adapted for use with cold pots and common household food quantities.

Cooking level	Heat-Up Time (seconds)
1	48
2	144
3	230
4	312
5	408
6	120
7	168
8	216
9	Not available
P	Not available

Activation:

The pots are positioned and the hob is active with a level of between 1 and 8 for the cooking zone (2). Select the cooking zone concerned.

Touch and hold the cooking level on the selection bar (4) for 3 seconds.

On the Display (2) a flashing **A** appears which alternates with the power set in the cooking zone.

By increasing the power level of the cooking zone, the Heat-Up function remains active, with the new temperature setting;

By decreasing the power level of the cooking zone, the Heat-Up function is deactivated.

Deactivation:

Touch and hold the cooking zone (2) for 3 seconds.

Rapid heating is deactivated and the cooking zone is heated with the previously set cooking level.

Alternative: Select a cooking level lower than the level currently set for this cooking zone. Rapid heating is deactivated. The cooking zone is heated up with the new cooking level.

➤ Warming function (Keeping warm)

This function keeps cooked food warm at a constant temperature.

The function is activated when the key **SSS**(8) is pressed for the first time.

The symbol **U** appears on the display (2) of the zone that is working with the "Warming" function active.

By selecting another cooking zone at the same time, the symbol **SSS** (8) will once again have a dim light, and it will therefore be possible to activate the function for this zone as well. However, the function remains active in the zone in which it has already been set, as indicated on the Display (2).

Press the key **SSS** (8) again to deactivate and switch off, until bringing the level shown on the display (2) to 0.

If the "Warming" function is active on several cooking zones, first select the desired zone using the Selection Display (2). This function can also be deactivated via the Selection Bar (4), bringing the Power level to 0.

➤ Pause function

The Pause function suspends any active function on the hob, bringing the cooking power to 0.

To activate the function, press || (Pause, 10) and the cooking zone displays (2) will show a steady light **||**

To deactivate the function, press || (Pause, 10), tap the Selection Bar (4) and the function will deactivate.

Deactivation restores the conditions of the hob before the pause and the hob continues to work with the same settings previously set.

Attention: the hob must never be left unattended while the pause function is active.

10 minutes after activation of the Pause Function, if it is not deactivated, the hob switches off automatically.

The Pause Function does not suspend extraction.

➤ Recall Function

This function is used to recover the power levels, timer settings and rapid heating after the hob has been switched off inadvertently.

If the hob is switched off and on again within 6 seconds, all the previous settings (power levels, timer, rapid heating) will be recovered automatically.

The recall function cannot be deactivated by the user.

Activation:

The hob has been switched off.

Turn the hob on again using ON/OFF (1).

The Pause key || (10) flashes for 6 seconds.

Touch the Pause || key (10).

The recall function becomes active (an acoustic “beep” is emitted). All the previously set power levels, timers and rapid heating are restored.

➤ Autonomous Timer Function

The independent Timer function is a countdown independent of the cooking zones and extraction which emits an acoustic signal (beep) when it expires.

The Timer is activated by pressing the central key **B** (5) between the two + / - keys (6).

When the Display shows “---” then the Timer can be set.

Set the desired duration of the timer using the + / - keys (6) and it will be shown on the display (5).

The timer starts 10 seconds after activating this function (by not pressing any other command).

The format of the autonomous Timer is **000**

The timer can be set up to a maximum of 600 minutes.

The remaining time will be displayed in the Zone/Display (5); at the end of the countdown an acoustic signal (beep) will be emitted.

If the remaining time of the timer is less than 1 minute, it will be displayed in the format shown below and the dot will have a steady light:

. -> minutes

00 -> seconds

To turn off the Timer, proceed in two ways:

-> select **8** (5) and set the duration of the Timer to **0.00**, using + / - (6)

or

-> press the ON/OFF key (1) twice

➤ Cooking zone timer

On each cooking zone, even simultaneously, it is possible to set the Cooking Zone Timer function which is a countdown.

At the end of which the cooking zones switch off automatically, emitting an acoustic signal (beep).

To activate the function:

-> touch the Selection/Display area (2) with a power level other than 0

-> touch the key  (3) relating to the cooking zone

-> the display shows “---“ and the Timer can be set.

-> set the duration of the timer, with the + / - keys (6), which is displayed in the Display area (5)

During programming the symbol  (3) flashes.

The cooking zone timer starts 10 seconds after activation (without pressing any other key).

To reset the timer with cooking, press and hold the key  (3) again

If desired, the Timer programming can be repeated for several cooking zones.

Each cooking zone can have a different Timer set and the display (5) will show the countdown of the cooking zone selected at that moment.

If no zone is selected, pressing on the Display (5) the countdown of the Autonomous Timer is displayed.

The countdown display is the same as for the Autonomous Timer (see previous paragraph)

At the end of the countdown, an acoustic signal (beep) will be emitted and the cooking zone will switch off.

To stop the beep, press ON, or

To deactivate the Timer:

-> select the cooking zone (2) and set the duration of the Timer to **0.00** with the + / - keys (6)

➤ **Bridge Function**

This function allows both cooking zones to work at the same time forming a single cooking zone with the same power level.

This function allows homogeneous cooking with large pots.

The front "Primary" cooking zone can be used in combination with the corresponding "Secondary" one at the back.

The function is provided on all cooking zones:

2FL (primary) + 2RL (secondary)

2FR (primary) + 2RR (secondary)

Bridge Function Activation:

-> select the two cooking zones to be used at the same time

-> on the Display (2) of the "Secondary" cooking zone the symbol "7" appears

-> using the selection bar (4) it will be possible to set the operating level (power), which will be shown on the display (2) of the "Main" cooking zone

Deactivate the Bridge Function:

-> repeat the same activation procedure

Attention: during the Bridge Function, the cooking zones are considered a single cooking area and therefore, if the Cooking Zone Timer is active, when it expires it will cause both cooking zones to switch off automatically.

➤ Power table

Power Level		Cooking type	Recommended use
Maximum	Booster	Quick heating	Ideal to quickly raise the temperature of food up to rapid boiling in the case of water or to quickly heat cooking liquids
	8-9	Frying, boiling	Ideal for browning, starting cooking, frying frozen products, boiling quickly
High	7-8	Browning, frying, boiling, grilling	Ideal for frying, maintaining a lively boil, cooking and grilling (for a short time, 5-10 minutes)
	6-7	Browning, cooking, stewing, frying, grilling	Ideal for frying, maintaining a light boil, cooking and grilling (for medium duration, 10-20 minutes), preheating accessories
Medium	4-5	Cooking, stewing, frying, grilling	Ideal for stewing, maintaining a delicate boil, cooking (for a long time). Stirring sauce into pasta
	3-4	Cooking, simmering, thickening, stirring	Ideal for prolonged cooking (rice, sauces, roasts, fish) in the presence of accompanying liquids (e.g. water, wine, broth, milk), stirring
	2-3	Cooking, simmering, thickening, stirring	Ideal for prolonged cooking (volumes less than a litre: rice, sauces, roasts, fish) in the presence of accompanying liquids (e.g. water, wine, broth, milk)
Low	1-2	Melting, defrosting, keeping warm, stirring	Ideal for softening butter, gently melting chocolate, defrosting small products
	1	Melting, defrosting, keeping warm, stirring	Ideal for keeping small portions of freshly cooked food warm or keeping serving dishes warm and stirring risottos
Off	0	None, support surface	Hob in stand-by or off position (possible presence of residual heat from the end of cooking, indicated with H)

IV.4 EXTRACTION

IV.4.a PRELIMINARY INDICATIONS

To turn on the aspiration, firstly open the glass flap (Fig. 4.4.a.1)

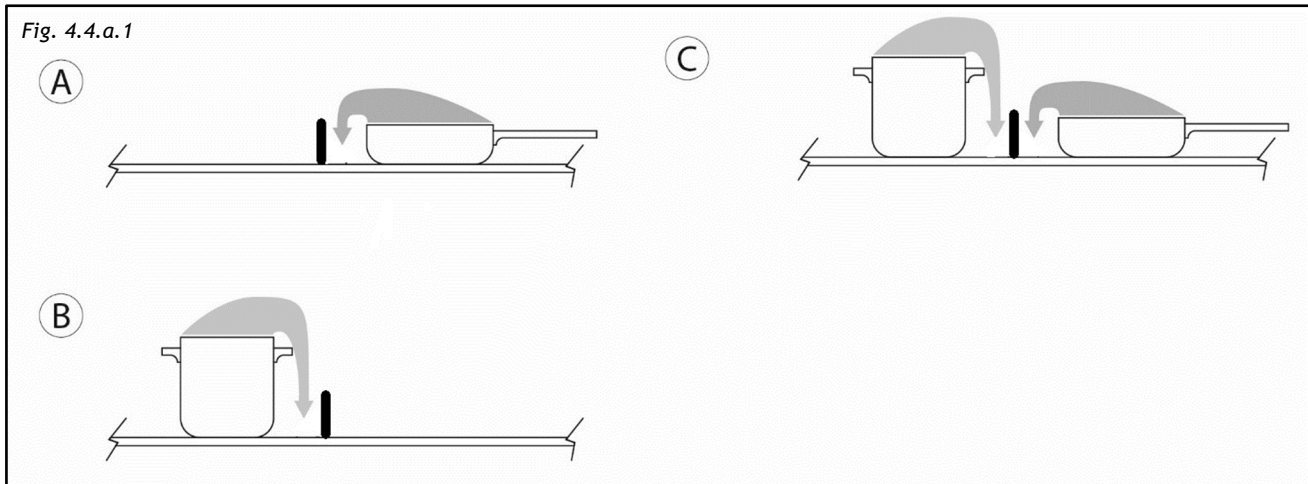

To open the glass flap, simply press on any point on the outside of the flap itself (Fig. 4.4.a.2).

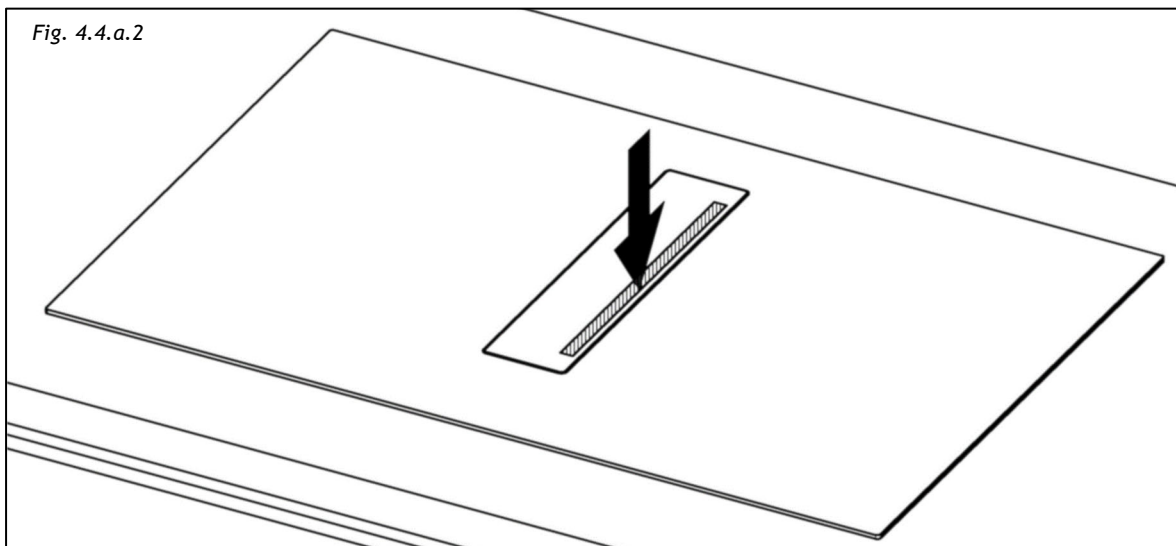

To facilitate better extraction of the fumes, try to make them exit from the part closest to the extraction (Fig. 4.4.a.3).

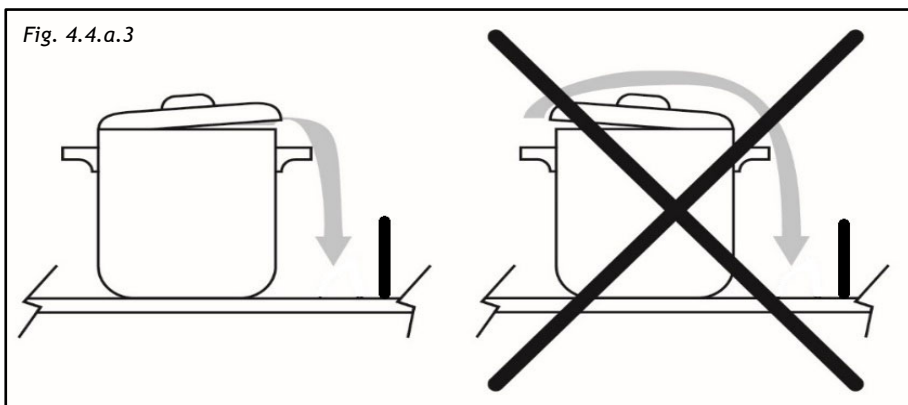

Do not place any objects on the glass flap or on the control panel (Touch Control "TC") (Fig.4.4.a.4).

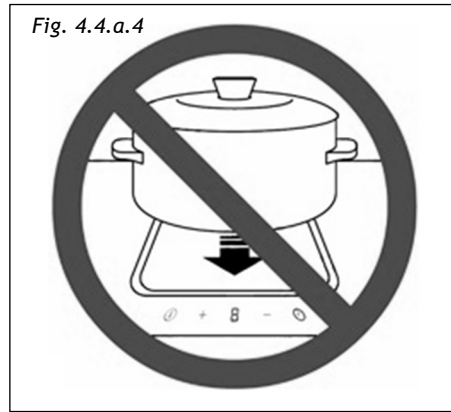

IV.4.b EXTRACTION OPERATION

➤ Turning on the extraction system:

- > Open the central glass flap.
- > Touch the ON/OFF key for a few seconds and the symbol will light up. ①
- > Touch the Selection area (12) to activate the extraction system.

Attention: the extraction area is equipped with a mechanical rotating central flap. The flap must be opened before activating the extraction system.

The opening flap has an electronic sensor that deactivates the suction when it is closed, this is to preserve the motor, which would be damaged by operating without air flow.

If, inadvertently, while suction is activated, the flap is completely closed, it will be possible to reactivate suction by reopening it.

➤ Extraction speed (power):

The extractor is equipped with 9 levels of extraction speed (power).

Touch and slide your fingers along the Selection Bar (4) to increase or decrease:

- to the right to increase the power level;
- ← to the left to decrease the power level.

The power level set will be displayed in the Selection/Display area (12)

➤ Booster function "P" (Enhanced Extraction)

The extractor is equipped with an additional power level (Booster, in addition to level 9).

The extractor will go to the supplementary speed (Booster) for 5 minutes and then it will automatically switch to level 9.

To activate the Booster function, scroll with your fingers along the selection bar (4) beyond level 9 up to "P".

Booster level is indicated in the Selection/Display area (12) with symbol **P**

➤ Automatic Operation

By activating this function, the appliance will switch on at the most suitable speed, adapting the extraction capacity to the maximum cooking level used in the cooking zones.

When the cooking zones are switched off, the appliance adapts its extraction speed, progressively decreasing it, removing odours and residual vapours.

Activation:

-> Press the specific key  (14)

Deactivation:

-> Press the specific key again  (14)

If the hob with Automatic operation active is switched off, the extractor will switch off automatically, gradually.

➤ Adjustable and Delayed self-switching Off

This function ensures the extraction of any odours and residual vapours. After completing the cooking process and switching off the hob, the fan continues to run.

There is automatic 5-minute operation at level 1 which starts in the following cases:

-> manual switching off of the hob (ON/OFF) with extractor active

-> shutdown of the extractor in automatic mode using an algorithm

When the function is active in the display (12) point a flashes in the bottom right .

When the automatic mode is active, the symbol  remains; in manual mode, level 1 is displayed.

In general, the fan speed can be changed even during execution of the function and ends immediately if 0 is selected.

➤ Extraction timer

It is possible to set an extraction timer similar to that of the cooking zone.

Press on the display (5) and act on "+" and "-" to set the desired timer.

The timer is shown on the Display (5). The timer only starts running when the cooking process is finished and no further cooking level is set.

The extraction timer can be activated in the following ways:

1. Manual mode 1

-> Both the extraction level and the timer are set and all the cooking zones are switched off.

-> The hob remains on and the suction level remains active for the timer time.

-> Once the timer has elapsed, the hob switches off completely.

2. Manual mode 2

- > Both the suction level and the timer are set and the hob is switched off via the ON/OFF button
- > Level 1 of the “Adjustable and Delayed self-switching Off” function is set and remains active for the time set in the timer.
- > At the end of the time set in the timer, the hob switches off completely.

3. Automatic mode

- > The timer can be set as soon as the extraction is running and starts working as soon as all the cooking zones are switched off.
- > There is no timer warning after the “Adjustable and Delayed self-switching Off” function expires.

➤ Filter cleaning alert

This function is programmed to alert to the fact that maintenance is due:

Grease filters: every 30 hours

Long life ceramic odour filters: every 120 hours (deactivated by default)



If the anti-odour warning is activated, it will be signalled even if the appliance is not installed in filtering mode: in this case proceed with normal cleaning of the grease filters and reset the warning.



Activation / Deactivation:

- > Access the User Menu (see HOB CONFIGURATION paragraph) and set it according to your requirements by following the instructions in the items Overview table (Fig.4.3.c.2) to the code "U1".

Filter cleaning indicator reset:

If the grease filter timer expires, the symbol  (13) comes on with a fixed light. It must be pressed for 5 seconds to reset the filter timer, a **F** appears on the display (12) and the warning count starts again.

If the odour filter timer expires, the symbol  (13) will flash. It must be pressed for 5 seconds to reset the filter timer, a  appears on the display (12) and the warning count starts again.

If both filter timers have expired, the symbol  (13) lights up steadily. The grease filter timer must be pressed for 5 seconds; a **F** will appear on the display (12). After that, the symbol  (13) comes on flashing. It must be pressed for 5 seconds to reset the odour filter timer, a  appears on the display (12) and the warning count starts again.

V MAINTENANCE AND CLEANING



Attention! Before any maintenance or cleaning operation, disconnect the power supply from the appliance (Fig. 2.1 - Fig. 2.2 WARNINGS chapter).

V.1 CLEANING THE EXTRACTOR INDUCTION HOB

Turn off the appliance before cleaning it.

Do not clean the hob if the glass is too hot as there is a risk of burns.

Remove light stains with a cloth dampened with dish detergent diluted in a little water. Then rinse with cold water and dry the surface thoroughly.

Highly corrosive or abrasive cleaners and cleaning equipment that can cause scratches should be strictly avoided.

Never use pressure or steam appliances.

Do not use objects that could scratch the ceramic glass.

Make sure the pot is dry and clean. Make sure there are no specks of dust on the glass ceramic hob or on the pot. Sliding rough pans will scratch the surface.

Spills of sugar, jam, jelly, etc. must be removed immediately. This will prevent damage to the surface.

Warning! The following products must **NOT** be used:

Products containing chlorides, especially those containing hydrochloric acid;

Products based on halides;

Products based on hydrogen peroxide;

Bleaches based on hypochlorous acid;

Aggressive products containing acids;

Detergents containing abrasive powder;

Silver cleaning products;

Detergents whose chemical composition is unknown;

Abrasive pads, brushes or discs;

Rough cloths or rough paper;

Tools that have previously cleaned other metals or alloys.

Ordinary cleaning

Do not let dirt accumulate on the external and internal surfaces of the appliance.

For the central glass flap, follow the same instructions indicated for cleaning the induction hob.

Attention: the flap cannot be washed in the dishwasher.

Routine cleaning must be carried out before an excessive accumulation of dirt is created which can cause abrasive phenomena.

Before carrying out the washing operations, it is necessary to remove any dust particles by blowing or suctioning them, in order to avoid rubbing on the surface.

Where water has been used as a means of cleaning or rinsing, especially in areas with a significant presence of limescale, it is advisable to dry the surface to prevent the appearance of stains.

To avoid contamination caused by iron particles, make sure that the tools chosen for cleaning have not been used previously on other metals or alloys.

Materials for cleaning stainless steel products must be exclusively reserved for this purpose.

Particular care must be paid to the grease filter, which has the function of retaining the grease particles contained in the vapours, and to the tray below, which has the function of collecting the grease that could drip from the grease filter. Collect the condensation or collect the liquids accidentally poured into it through the glass flap.

Both of these elements must be washed when the relevant warning appears or at least once a month in hot water and detergent, even in the dishwasher, at a temperature not exceeding 50°C.

The filter may become discoloured after a few washes. This is normal and does not mean it has lost its effectiveness.

To perform maintenance on the metal grease filter and on the tray underneath, it is essential to remove them from the appliance.

To remove the metal grease filter and the tray, proceed as shown in Fig. 5.1.1:

- > Push down the right side of the central glass flap
- > Remove the central glass flap (1)
- > Grip the metal grease filters by the knob and remove them (2)
- > Remove the condensate collection tray (3)

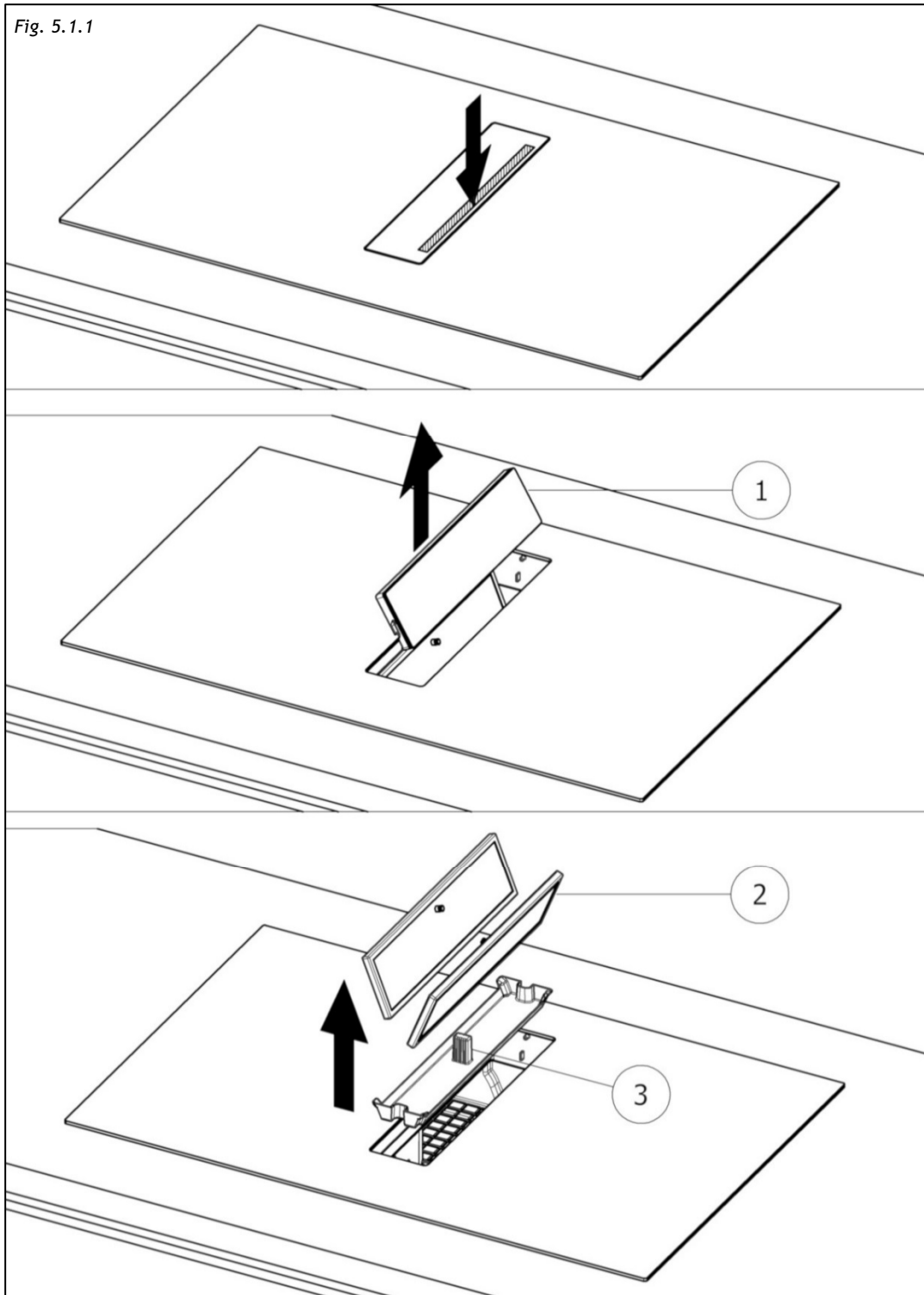

After performing these operations, all the components that have just been removed can be cleaned. After cleaning, the components must be dried and finally repositioned by carrying out the operations indicated above (Fig. 5.1.1) in reverse order.

The long life ceramic anti-odour filters, if present, have the function of retaining unpleasant odours deriving from cooking and must be regenerated when the relative warning appears.

To regenerate the ceramic odour filters they must be removed from the appliance.

To remove the ceramic anti-odour filters, proceed as illustrated in Fig. 5.1.2:

- > Push down the right side of the central glass flap
- > Remove the central glass flap (1)
- > Grip the metal filters by the knob and remove them both (2,3)
- > Grip the ceramic odour filters and remove them (4)

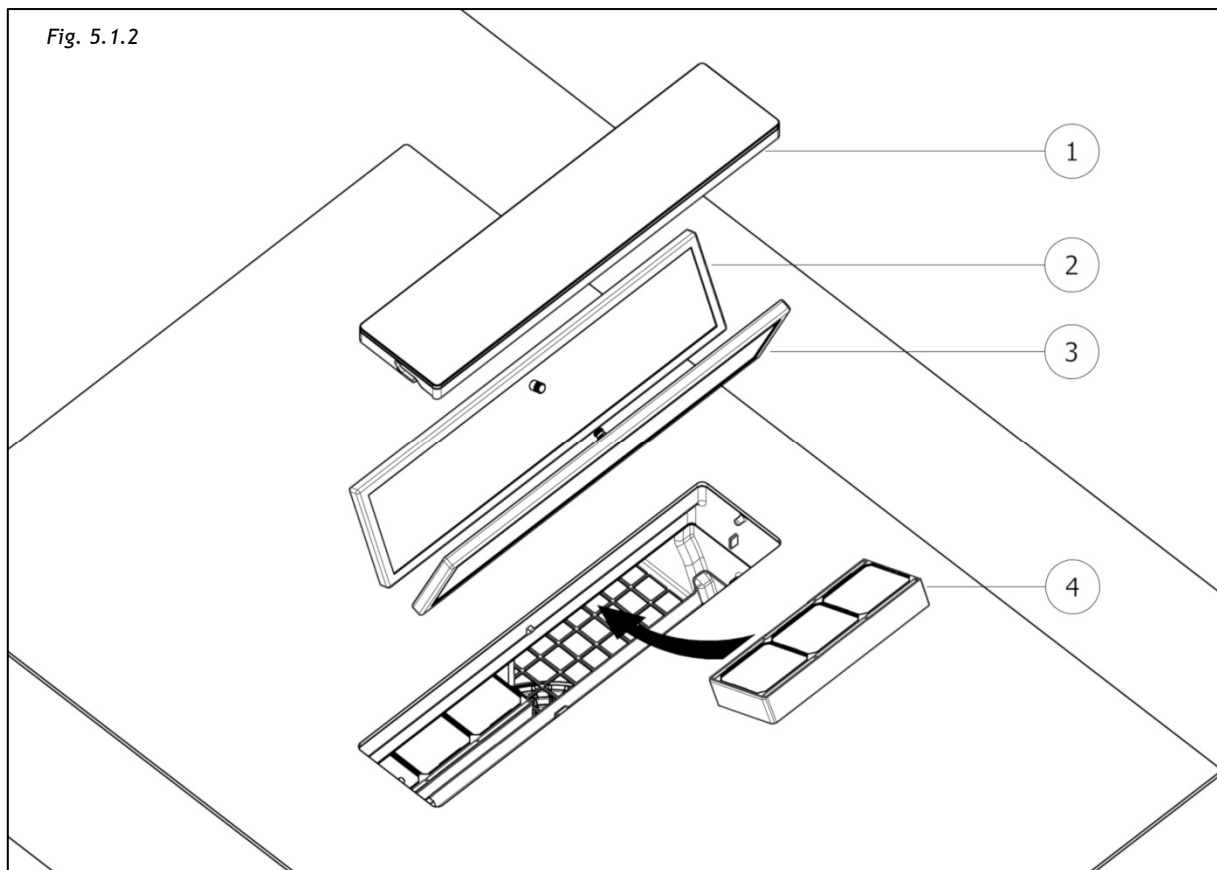

To regenerate thermally the long life ceramic anti-odour filters, they must be placed in a domestic oven at 100°C for 2/3 hours. Correct regeneration ensures constant filtering efficiency for 5 years. Attention! Do not place the filters on the bottom of the oven, but instead in a tray and place it at an intermediate height.

To purchase a new filter, request it from the manufacturer.

The appliance is equipped with a **safety cap** to empty any liquids accidentally spilled into the condensate collection tray, but which have exceeded its capacity. Check daily that there is no liquid inside the external tank of the hob. To do this, remove the cap under the hob, being sure to place a container first, under and at the cap itself, to collect any liquids present (see Fig. 5.1.3).

Fig. 5.1.3

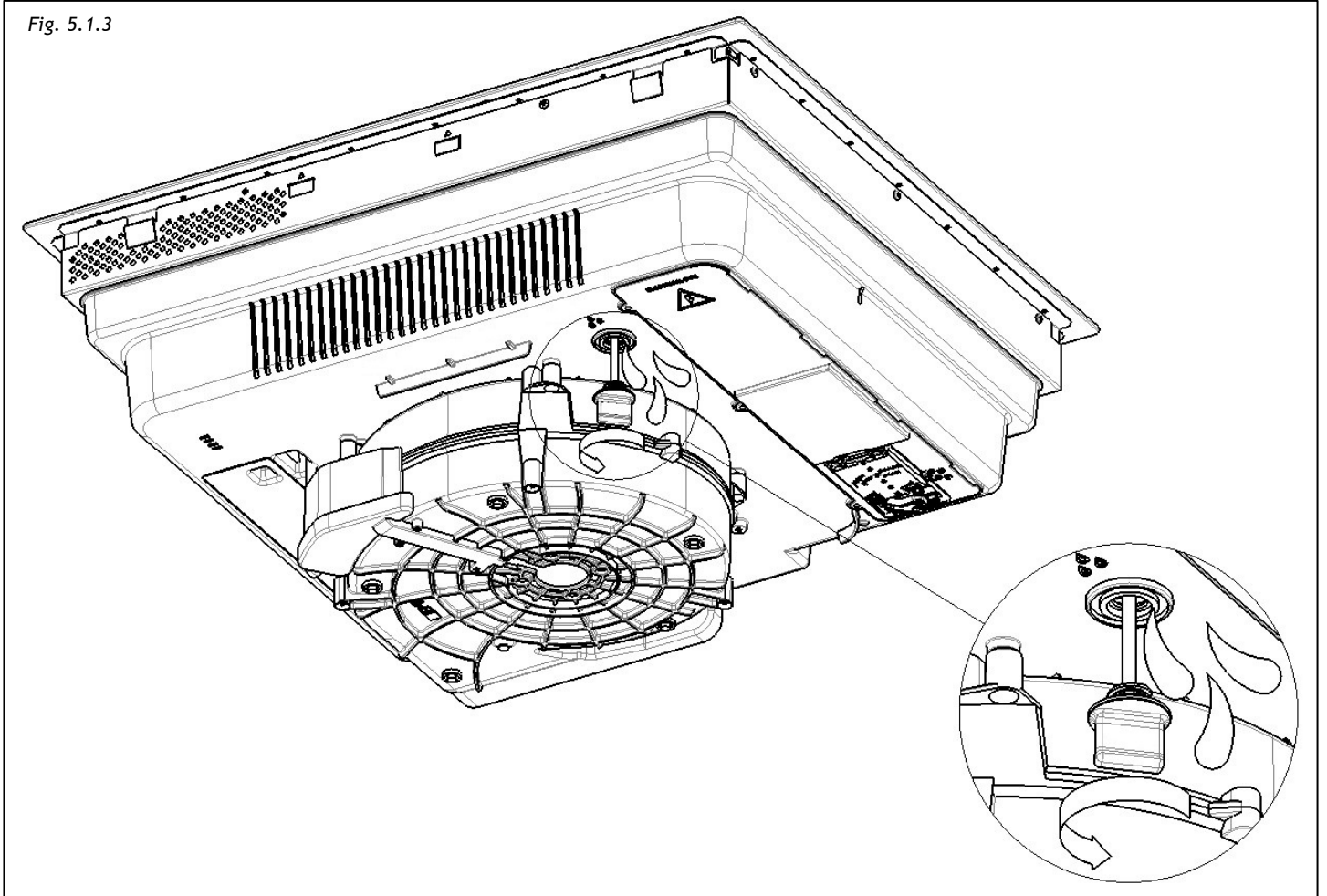

VI TROUBLESHOOTING

Warning! During the warranty period, repairs may only be carried out by the authorised After-Sales Assistance Service.



Attention! Before any maintenance or cleaning operation, disconnect the power supply from the appliance (Fig.2.1 - Fig. 2.2 WARNINGS chapter).

- Unauthorised interventions and repairs can cause electric shock or short circuit so avoid performing them. Leave these tasks to authorised technicians.
- In the event of small problems, you can try to resolve the problem by following the tips in the user instructions.
- The removal of faults or complaints caused by incorrect use or installation of the appliance will not be covered under warranty. The repair costs will be borne by the user.

VI.1 ERRORS / TROUBLESHOOTING

The hob is programmed to provide dedicated error codes for quick and efficient troubleshooting. The cooking zone displays show error codes.

An error code always begins with the letters “E” or “ER” depending on the electronic component that generated the error.

Error Code	Meaning Error	Behaviour of the hob	Cause possible	Solution Problem
ER03	Continuous activation of a key has been detected	Shutdown after 10 seconds	Water or pots placed on the TC*	Remove water or pots from the TC*
ER20	Internal error at TC*	Shutdown	-	Replace TC*
ER21	Overheating	Shutdown	The temperature sensor on TC* has detected a temperature > 85°C	Let the hob cool down (the error disappears if the temperature is < 75°C). Check the thermal insulation of the TC*
ER22	Internal error at TC*	Switch off after 3.5 - 7.5 seconds	-	Replace TC*

ER31	The internal configurations of the TC* and induction are incongruous	ER31 is displayed continuously	The internal configuration data of the induction generator is different from the configuration inside the TC*	Download the configuration. If the error is still present, replace the TC*. If the error is still present, replace the induction generator.
ER35	Internal error at TC*	Shutdown	-	Replace TC*
ER36	Internal error at TC*	Shutdown	-	Replace TC*
ER42	Secondary power supply not suitable	12V or 5V too high / too low		
ER47	No communication to at least one coupled LIN	ER47 is displayed continuously	Damaged LIN cable. No supply voltage for coupled LIN. Faulty coupled LIN.	Check and replace the LIN wiring. Check the supply voltage. Replace coupled LIN.

(*) TC = Touch Control (Control Panel)

VI.2 ASSISTANCE SERVICE

Before contacting the Assistance Service it is important to:

-> Check if the problem can be resolved by consulting the error table in the "Errors/Troubleshooting" paragraph.

-> Switch the appliance off and on again (ON/OFF) to make sure that the problem has been resolved.



Finally, if after carrying out the above checks the error signals persist, contact the Assistance Service.

VII DECOMMISSIONING

VII.1 DECOMMISSIONING

Decommissioning means the definitive shutdown and dismantling of the appliance.

After decommissioning, the appliance can be incorporated into another unit, resold privately or disposed of.

	Attention! To put it out of service, it is necessary to switch off the appliance and disconnect the power supply from the appliance (Fig. 2.1-2.2 WARNINGS chapter).
	Attention! Only have the electrical lines disconnected and closed by specialist personnel.

VII.2 DISASSEMBLY

Disassembly requires that the device is accessible for disassembly and has been disconnected from the voltage supply.

To do this, proceed as follows:

- Loosen the screws and fixing brackets
- Remove any silicone sealants
- Pull the hob out from above

VII.3 PROTECTING THE ENVIRONMENT

The packaging materials are environmentally-friendly and recyclable.

The electronic devices consist of materials that are recyclable but sometimes harmful for the environment, but necessary for the correct functioning and safety of the appliance.

VII.4 DISPOSAL



This appliance is marked in accordance with the European Directive 2012/19/EC, Waste Electrical and Electronic Equipment (WEEE).

The symbol on the product or on the packaging indicates that the product must not be treated as normal household waste, but must be taken to the appropriate collection point for the recycling of electrical and electronic equipment.

By ensuring that this product is disposed of correctly, you will help prevent potential negative consequences for the environment and for human health. For detailed information about recycling this product, contact your council, your local waste collection service or the store where you purchased the product.

