

Technical Data Sheet - HIDE new Plasma

Product Photo



1. Product Identification

Model	HIDE new Plasma
Installation	Built-in
Product line	Plasma

2. Dimensions and structure

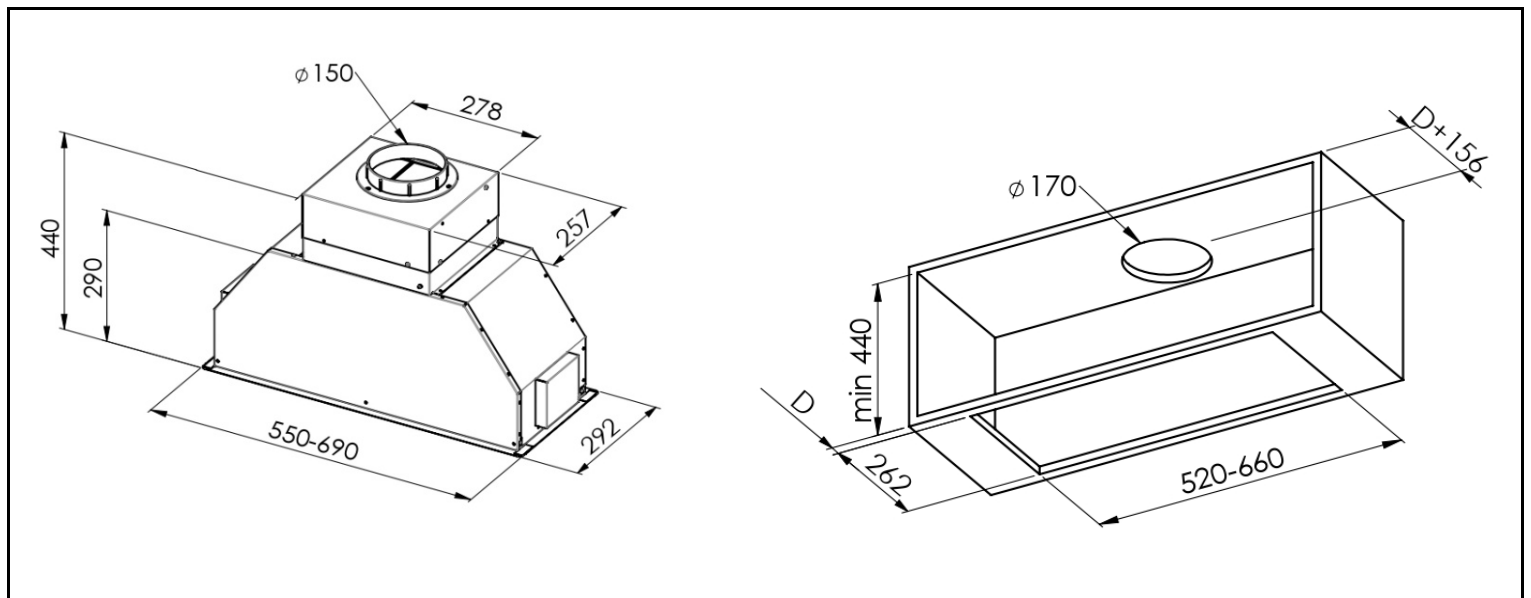

Length	60 - 80 (cm)
Height	44,0 (cm)
Depth	29,2 (cm)
Finish	inox

3. Suction performance

Air flow (Min/Max/Booster)	450 (m ³ /h)
Speed	3 + B
Controls	Backlit soft touch controls
Static Pressure	590 (Pa)
Version	Recycling

4. Lighting

Type	LED bar
Number	1
Power	4W x 60 cm, 6W x 80 cm
Dimmable	Adjustable from 0 to 152 Lux
Temperature	Adjustable from 2700K to 6000K

5. Noise

Min/Max/Booster	48 / 65 / 72 dB(A)
-----------------	--------------------

6. Electrical data

Voltage	220-240V / 50Hz - 220V / 60Hz
Maximum power consumption	289W x 60cm – 291W x 80cm

7. Filtration and odors

Grease filters	Dishwasher-safe aluminum filters. Cod. R258112 (2pcs x 60) R258111 (2pcs x 80)
Odor filters	Plasma

8. Installation

Minimum height from gas hob	60 (cm)
Motor outlet diameter	150 (mm)

9. Certifications

Energy Class	N.R.
--------------	------

10. Weight and Transport

Net Weight	60cm Kg 11,50 - 80cm Kg 12,45
Gross Weight	60cm Kg 14,50 - 80cm Kg 15,45
Packaging Dimensions WxDxH	(60) 630x370x540mm (80) 930x370x540mm
Pieces per pallet / pallet size	(60) 16pcs / 80x120cm (80) 12pcs / 100x120cm

11. Accessories

Remote control with holder	Cod. 00BTE05BF500

12. Product Plus

Light indicator for anti grease filters maintenance
Adjustable and delayed self-switching off
Perimeter extraction
Easy cleaning: the bottom panel can be easily removed without the use of tools.

Date: 07/10/2025

Revision:

